

Solutions Manual

to accompany

STRUCTURAL DYNAMICS
Theory and Applications

2.1

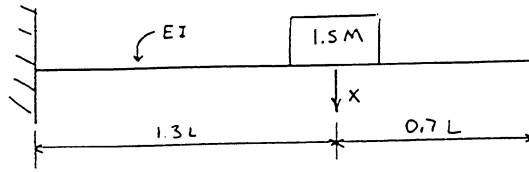

SOLUTION

d'ALEMBERT'S PRINCIPLE

$$\sum (\text{FORCES})_x - m\ddot{x} = 0$$

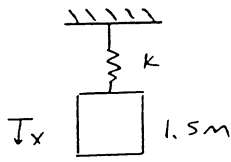

FBD

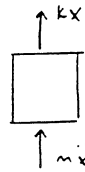

$$kx + m\ddot{x} = 0$$

$$\ddot{x} + \frac{k}{m}x = 0 \quad \text{EQUATION OF MOTION}$$

$$k = \frac{3EI}{(1.3L)^3}$$

$$\omega = \sqrt{\frac{k}{m}} = \sqrt{\frac{3EI}{1.5M(1.3L)^3}} = 0.954 \sqrt{\frac{EI}{ML^3}}$$

2.2

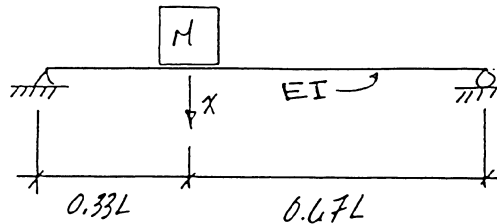

Solution:

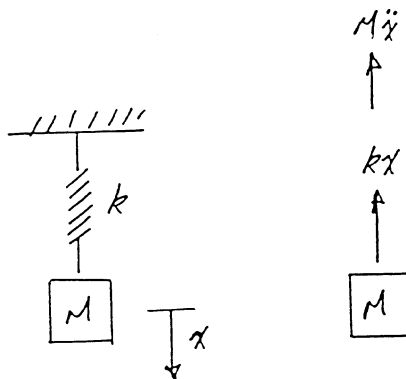

2.2 Cont.

Equation of motion: $M\ddot{x} + kx = 0$ or $\ddot{x} + \frac{k}{M}x = 0$

$$k = \frac{6EIL}{(0.33L)(L-0.33L)[2L(0.33L) - (0.33L)^2 - (0.33L)^2]}$$

$$k = \frac{61.37EI}{L^3}$$

Natural Frequency: $\omega = \sqrt{\frac{k}{M}} = 7.834 \sqrt{\frac{EI}{ML^3}}$

2.3

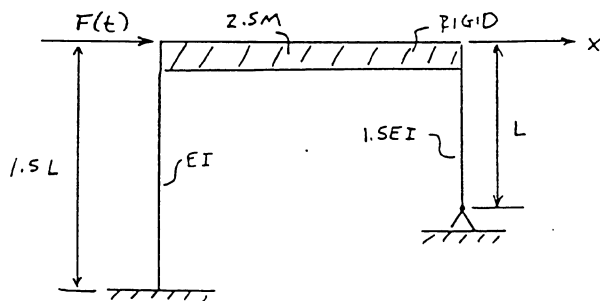

SOLUTION

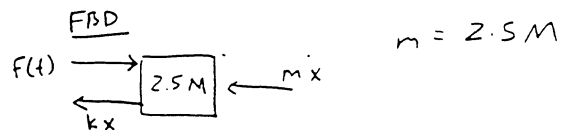
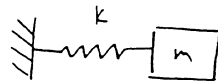

$$\sum (\text{FORCES})_x - m\ddot{x} = 0$$

$$F(t) - kx - m\ddot{x} = 0$$

$$\ddot{x} + \frac{k}{m}x = \frac{F(t)}{m}$$

EQUATION OF MOTION

$$k = \frac{12EI}{(1.5L)^3} + \frac{3(1.5EI)}{L^3}$$

$$= \frac{12(30 \times 10^6)(150)}{(1.5 \times 12 \times 12.0)^3} + \frac{3(1.5)(30 \times 10^6)(150)}{(12.0 \times 12)^3}$$

$$= 12,140 \text{ lb/in}$$

$$\omega = \sqrt{\frac{k}{m}} = \sqrt{\frac{12,140 \text{ lb/in}}{2.5(1.0 \text{ lb}\cdot\text{sec}^2/\text{in})}} = 69.7 \text{ rad/sec}$$

2.4

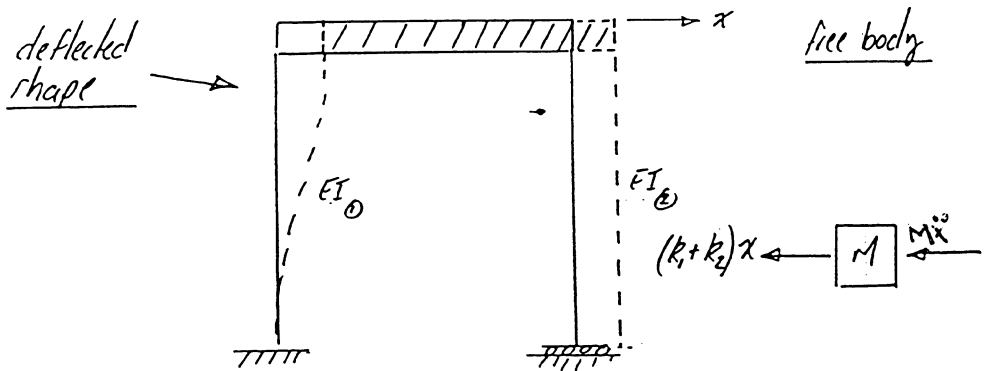
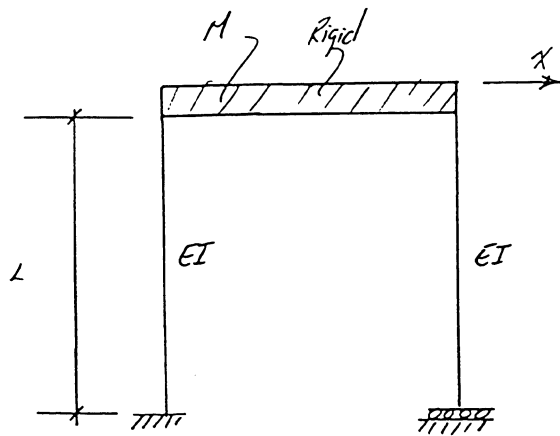

equation of motion: $M\ddot{x} + kx = 0$ or $\ddot{x} + \frac{k}{M}x = 0$ ANS

$k_0 = \frac{12EI}{L^3}$

$k_0 = 0$

natural freq. : $\omega = \sqrt{\frac{k}{M}} = \left(\frac{12EI}{ML^3}\right)^{1/2}$ ANS

2.5

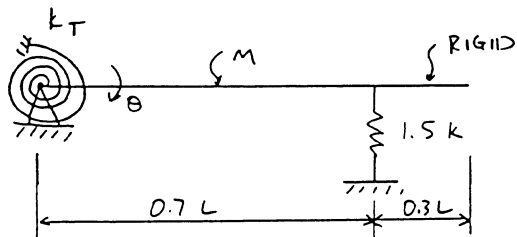

2.5 Cont.

SOLUTION

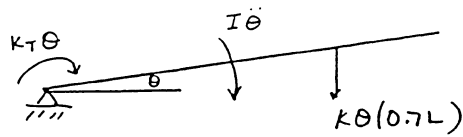

$$\Delta = 0.7L \sin \theta \approx 0.7L \theta \quad \text{FOR SMALL } \theta$$

$$I = \frac{mL^2}{3} \quad (\text{ABOUT PIVOT } \pi)$$

$$\sum M - I\ddot{\theta} = 0$$

$$k_T \theta + k(0.7L)\Delta + I\ddot{\theta} = 0$$

$$k_T \theta + k(0.7L)^2 \theta + I\ddot{\theta} = 0$$

$$\frac{mL^2}{3} \ddot{\theta} + k(0.7L)^2 \theta + k_T \theta = 0$$

$$\ddot{\theta} + \frac{3[k(0.7L)^2 + k_T]}{mL^2} \theta = 0 \quad \text{EQUATION OF MOTION}$$

$$\omega = \sqrt{\frac{3k(0.7L)^2 + 3k_T}{mL^2}} \quad \text{NATURAL FREQUENCY}$$

2.6

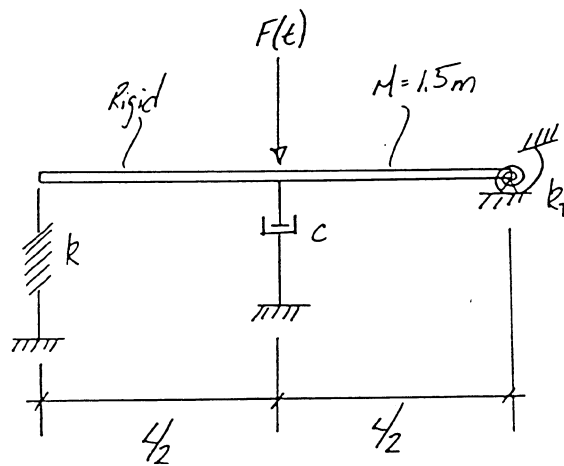

Solution:

free body

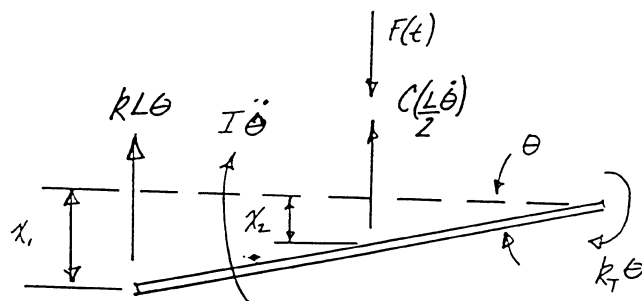

$$x_1 = L \sin \theta \quad \text{small disp} = L \theta$$

$$x_2 = \frac{L}{2} \sin \theta \quad \text{small disp} = \frac{L}{2} \theta$$

$$\dot{x}_2 = \frac{L}{2} \dot{\theta}$$

2.6 Cont.

$$I = \frac{ML^2}{3} = \frac{1.5ML^2}{3} = \frac{ML^2}{2}$$

equation of motion:

$$k_T \theta + kL\theta(L) + I\ddot{\theta} + c\left(\frac{L}{2}\dot{\theta}\right)\left(\frac{L}{2}\right) = F(t)\left(\frac{L}{2}\right)$$

$$k_T \theta + kL^2 \theta + I\ddot{\theta} + \frac{cL^2}{4} \dot{\theta} = F(t)\left(\frac{L}{2}\right)$$

$$I\ddot{\theta} + \frac{cL^2}{4} \dot{\theta} + (kL^2 + k_T)\theta = F(t)\left(\frac{L}{2}\right)$$

$$\left(\frac{ML^2}{2}\right)\ddot{\theta} + \frac{cL^2}{4} \dot{\theta} + (kL^2 + k_T)\theta = F(t)\left(\frac{L}{2}\right)$$

$$\ddot{\theta} + \frac{c}{2m} \dot{\theta} + \frac{2(kL^2 + k_T)}{ML^2} \theta = F(t)\left(\frac{1}{ML}\right) \quad \text{Ans}$$

natural frequency:

$$\omega = \sqrt{\frac{2(kL^2 + k_T)}{ML^2}} \quad \text{Ans}$$

2.7

$$\sum M_A = I_A \alpha$$

$$mL\ddot{\theta}(L) + mgL\sin\theta + k_T\theta = 0$$

$$mL^2\ddot{\theta} + (mgL\sin\theta + k_T\theta) = 0$$

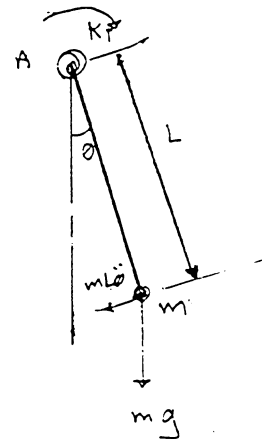

2.7 cont.

for small values of θ

$$\sin \theta = \theta$$

$$mL^2 \ddot{\theta} + (mgL + k_L) \theta = 0$$

$$\ddot{\theta} + \left(\frac{g}{L} + \frac{k_L}{mL^2} \right) \theta = 0$$

$$\omega = \sqrt{\frac{g}{L} + \frac{k_L}{mL^2}}$$

2.8

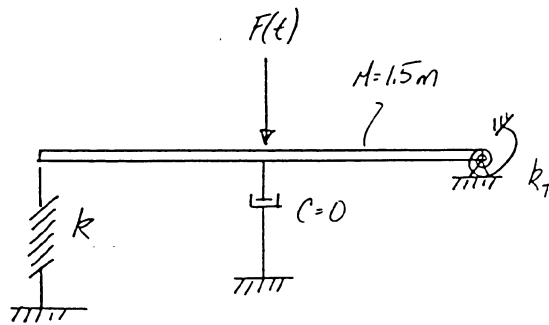

Assume a conservative system (i.e. no damping)

Solution:

free body

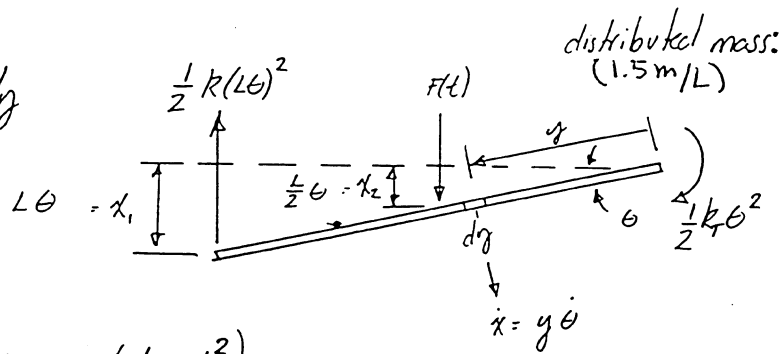

Kinetic Energy $\left(\frac{1}{2} mV^2 \right)$

$$\frac{1}{2} \int_0^L \frac{1.5m}{L} (y\dot{\theta})^2 dy = \frac{3}{4} \int_0^L \frac{m}{L} \dot{\theta}^2 y^2 dy = \frac{3}{4} \left(\frac{m}{3L} \dot{\theta}^2 y^3 \right) \Big|_0^L$$

$$T = \frac{mL^2 \dot{\theta}^2}{4}$$

2.8 cont.

Potential Energy

$$V = \frac{1}{2}k(L\theta)^2 + \frac{1}{2}k_T\theta^2 - F(t)\left(\frac{L}{2}\right)\theta$$

TOTAL WORK $(T+V) = \text{constant}$

$$\frac{mL^2\dot{\theta}^2}{4} + \frac{1}{2}k(L\theta)^2 + \frac{1}{2}k_T\theta^2 - F(t)\left(\frac{L}{2}\right)\theta = \text{constant}$$

$$\frac{d(T+V)}{d\theta} = 0 = \frac{mL^2}{2}\ddot{\theta} + kL^2\dot{\theta} + k_T\dot{\theta} - F(t)\left(\frac{L}{2}\right)\dot{\theta}$$

equation of motion:

$$\frac{mL^2}{2}\ddot{\theta} + (kL^2 + k_T)\theta = F(t)\left(\frac{L}{2}\right)$$

$$\ddot{\theta} + \frac{2(kL^2 + k_T)}{mL^2}\theta = F(t)\left(\frac{1}{mL}\right)$$

 ANS

natural frequency:

$$\omega = \sqrt{\frac{2(kL^2 + k_T)}{mL^2}}$$

 ANS

2.9

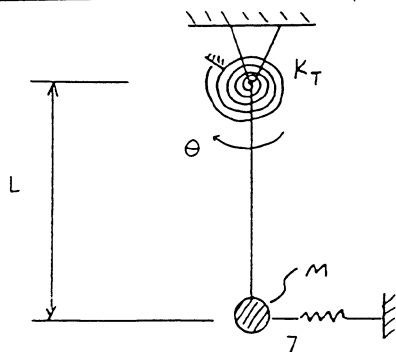

2.9 Cont.

SOLUTION

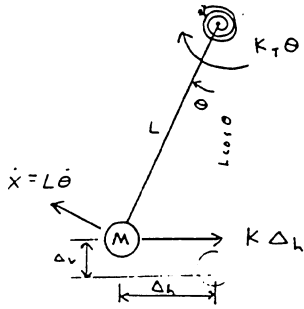

$$\Delta h = L \sin \theta \approx L \theta$$

$$\Delta v = L - L \cos \theta = L(1 - \cos \theta)$$

KINETIC ENERGY

$$T = \frac{1}{2} m \dot{x}^2 = \frac{1}{2} m (L \dot{\theta})^2$$

POTENTIAL ENERGY

$$V = mg \Delta v + \frac{1}{2} k \Delta h^2 + \frac{1}{2} k_T \theta^2$$

$$= mgL(1 - \cos \theta) + \frac{1}{2} k (L \theta)^2 + \frac{1}{2} k_T \theta^2$$

ENERGY METHOD

$$T + V = \text{CONSTANT}$$

$$\frac{d}{dt}(T + V) = 0$$

$$m L^2 \ddot{\theta} \dot{\theta} + mgL(\sin \theta) \dot{\theta} + k L^2 \theta \dot{\theta} + k_T \theta \dot{\theta} = 0$$

$$m L^2 \ddot{\theta} + mgL \sin \theta + k L^2 \theta + k_T \theta = 0$$

$$\ddot{\theta} + \left(\frac{MgL + kL^2 + k_T}{ML^2} \right) \theta = 0 \quad \text{EQUATION OF MOTION}$$

$$\omega = \sqrt{\frac{MgL + kL^2 + k_T}{ML^2}} \quad \text{NATURAL FREQUENCY}$$

2.10

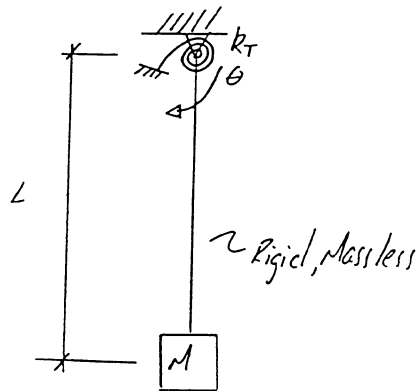

Solution:

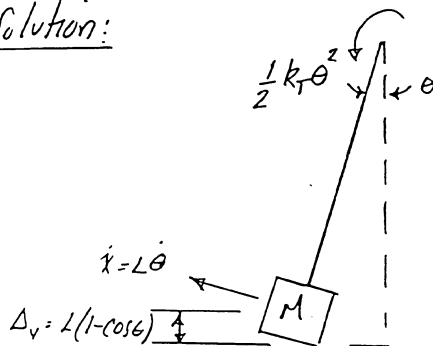

2.10 cont.

Kinetic Energy (T) $\frac{1}{2}mv^2$

$$\frac{1}{2}M(L\dot{\theta})^2$$

Potential energy: (V)

$$MgL(1-\cos\theta) + \frac{1}{2}k_T\theta^2$$

TOTAL WORK: (T+V)

$$\frac{1}{2}ML^2\dot{\theta}^2 + \frac{1}{2}k_T\theta^2 + MgL(1-\cos\theta) = \text{constant}$$

$$\frac{d(T+V)}{d\theta} = 0 = ML^2\ddot{\theta} + k_T\theta + MgL\sin\theta$$

$$ML^2\ddot{\theta} + k_T\theta + MgL\theta = 0$$

$$ML^2\ddot{\theta} + (k_T + MgL)\theta = 0$$

$$\ddot{\theta} + \left(\frac{k_T + MgL}{ML^2}\right)\theta = 0 \quad \text{ANS}$$

natural frequency:

$$\omega = \sqrt{\frac{k_T + MgL}{ML^2}} \quad \text{ANS}$$

2.11

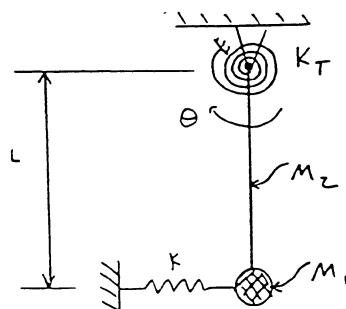

2.11 Cont.

SOLUTION

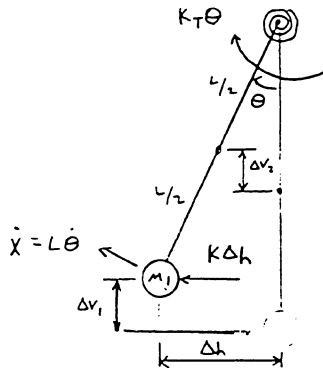

$$\Delta h = L \sin \theta \approx L \theta$$

$$\Delta v_1 = L(1 - \cos \theta)$$

$$\Delta v_2 = \frac{L}{2}(1 - \cos \theta)$$

$$T = \frac{1}{2} m_1 \dot{x}^2 + \frac{1}{2} I_0 \dot{\theta}^2$$

$$= \frac{1}{2} m_1 (L \dot{\theta})^2 + \frac{1}{2} (\frac{1}{3} m_2 L^2) \dot{\theta}^2$$

$$= \frac{1}{2} m_1 L^2 \dot{\theta}^2 + \frac{1}{6} m_2 L^2 \dot{\theta}^2$$

$$V = m_1 g \Delta v_1 + m_2 g \Delta v_2 + \frac{1}{2} k \Delta h^2 + \frac{1}{2} k_T \theta^2$$

$$= m_1 g L (1 - \cos \theta) + m_2 g \frac{L}{2} (1 - \cos \theta) + \frac{1}{2} k (L \theta)^2 + \frac{1}{2} k_T \theta^2$$

ENERGY METHOD

$$T + V = \text{CONSTANT}$$

$$\frac{d}{dt}(T + V) = 0$$

$$m_1 L^2 \ddot{\theta} + \frac{1}{3} m_2 L^2 \ddot{\theta} + m_1 g L (\sin \theta) \dot{\theta} + m_2 g \frac{L}{2} (\sin \theta) \dot{\theta} + k L^2 \theta \dot{\theta} + k_T \theta \dot{\theta} = 0$$

$$m_1 L^2 \ddot{\theta} + \frac{1}{3} m_2 L^2 \ddot{\theta} + m_1 g L \theta + m_2 g \frac{L}{2} \theta + k L^2 \theta + k_T \theta = 0$$

$$\ddot{\theta} + \frac{m_1 g L + \frac{1}{2} m_2 g L + k L^2 + k_T}{m_1 L^2 + \frac{1}{3} m_2 L^2} \theta = 0$$

EQUATION OF MOTION

$$\omega = \sqrt{\frac{m_1 g L + \frac{1}{2} m_2 g L + k L^2 + k_T}{m_1 L^2 + \frac{1}{3} m_2 L^2}}$$

NATURAL FREQUENCY

2.12

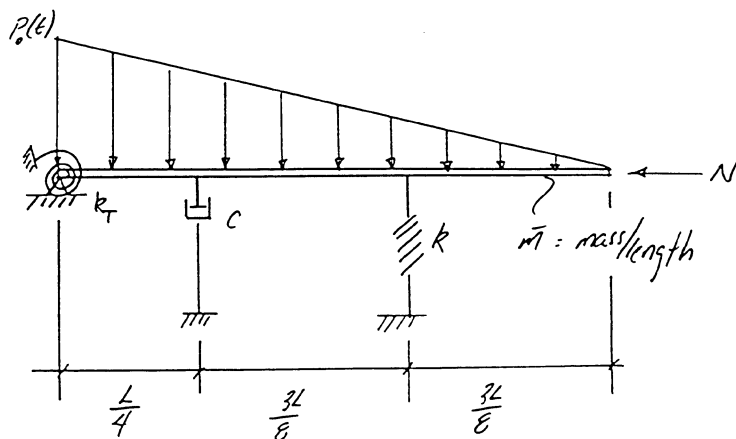

2.12 Cont.

Solution:

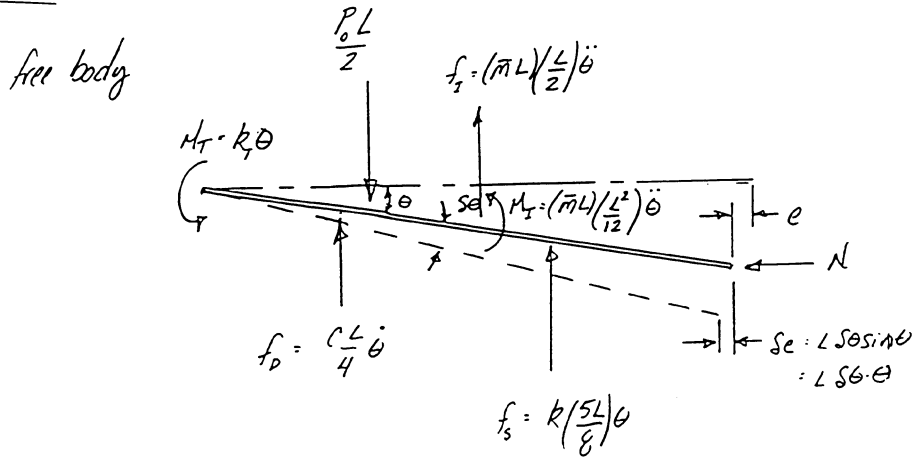

equation of motion:

$$-f_s \left(\frac{5L}{8} \sin \theta\right) - f_D \left(\frac{L}{4} \sin \theta\right) - M_T \sin \theta + N se + \frac{P_0 L}{2} \left(\frac{L}{3} \sin \theta\right)$$

$$\Rightarrow -f_s \left(\frac{L}{2} \sin \theta\right) - M_T \sin \theta = 0$$

$$- \frac{25 L^2 k \theta \sin \theta}{64} - \frac{c L^2}{16} \dot{\theta} \sin \theta - k_T \theta \sin \theta + N L \theta \sin \theta + \frac{P_0 L^2}{6} \sin \theta$$

$$\Rightarrow - \frac{\bar{m} L^3}{4} \ddot{\theta} \sin \theta - \frac{\bar{m} L^3}{12} \ddot{\theta} \sin \theta = 0$$

$$\Rightarrow - \frac{\bar{m} L^3}{3} \ddot{\theta} - \frac{c L^2}{16} \dot{\theta} - \left(\frac{25 k L^2}{64} + k_T - N L\right) \theta + \frac{P_0 L^2}{6} = 0$$

$$\boxed{\frac{\bar{m} L^3}{3} \ddot{\theta} + \frac{c L^2}{16} \dot{\theta} + \left(\frac{25 k L^2}{64} + k_T - N L\right) \theta = \frac{P_0 L^2}{6}} \quad \underline{\text{ANS}}$$

Natural frequency: $\omega = \sqrt{\frac{k}{m}}$

$$\boxed{\omega = \sqrt{\frac{\frac{25 k L^2}{64} + k_T - N L}{\frac{\bar{m} L^3}{3}}}} \quad \underline{\text{ANS}}$$

2.13

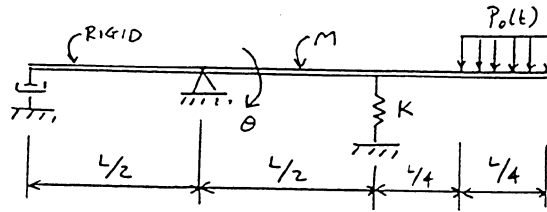

SOLUTION

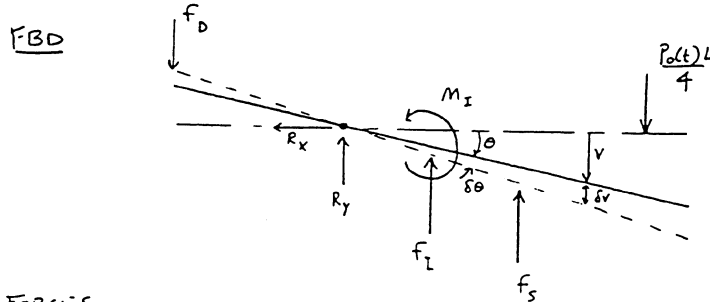

FORCES

$$f_s = K \left(\frac{L}{2} \right) \theta$$

$$f_D = c \left(\frac{L}{2} \right) \dot{\theta}$$

$$f_I = M \left(\frac{L}{4} \right) \ddot{\theta}$$

$$f_{P_0} = \frac{P_0 L}{4} f(t)$$

$$M_I = I \ddot{\theta} = \frac{ML^2}{12} \ddot{\theta}$$

PRINCIPLE OF VIRTUAL DISPLACEMENTS

$$\delta W = 0$$

IN CALCULATING THE VIRTUAL WORK, A QUANTITY IS POSITIVE WHEN THE FORCE ACTS IN THE SAME DIRECTION AS THE VIRTUAL DISPLACEMENT.

$$-f_s \left(\frac{L}{2} \delta \theta \right) - f_D \left(\frac{L}{2} \delta \theta \right) - f_I \left(\frac{L}{4} \delta \theta \right) - M_I (\delta \theta) + f_{P_0} \left(\frac{7}{8} L \delta \theta \right) = 0$$

$$-K \frac{L^2}{4} \theta \delta \theta - c \frac{L^2}{4} \dot{\theta} \delta \theta - M \frac{L}{16} \ddot{\theta} \delta \theta - \frac{ML^2}{12} \ddot{\theta} \delta \theta + \frac{7P_0(t)L^2}{32} \delta \theta = 0$$

$$\left[\left(\frac{ML^2}{16} + \frac{ML^2}{12} \right) \ddot{\theta} + \left(\frac{cL^2}{4} \right) \dot{\theta} + \left(\frac{KL^2}{4} \right) \theta \right] \delta \theta = \frac{7P_0(t)L^2}{32} \delta \theta$$

SINCE $\delta \theta \neq 0$

$$\frac{7ML^2}{48} \ddot{\theta} + \frac{cL^2}{4} \dot{\theta} + \frac{KL^2}{4} \theta = \frac{7P_0(t)L^2}{32}$$

EQUATION OF MOTION

$$\omega = \sqrt{\frac{\frac{KK^2}{4}}{\frac{7ML^2}{48}}} = \sqrt{\frac{12K}{7M}} \text{ RAD/SEC}$$

NATURAL FREQUENCY

2.14

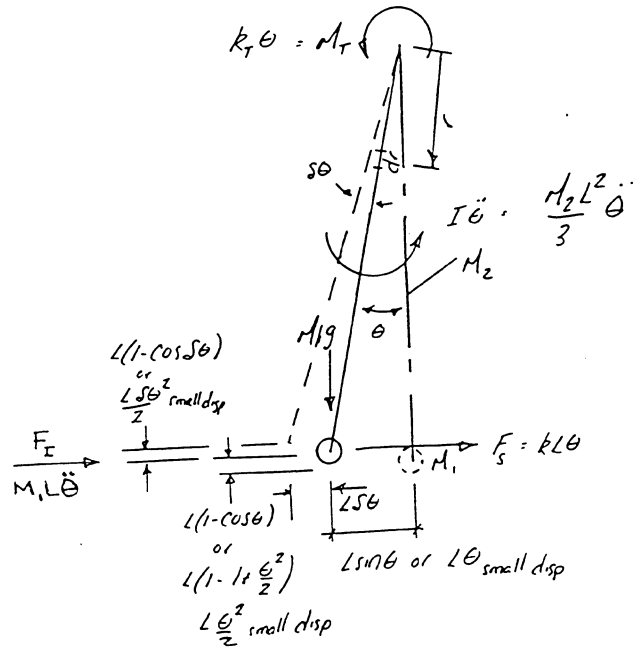
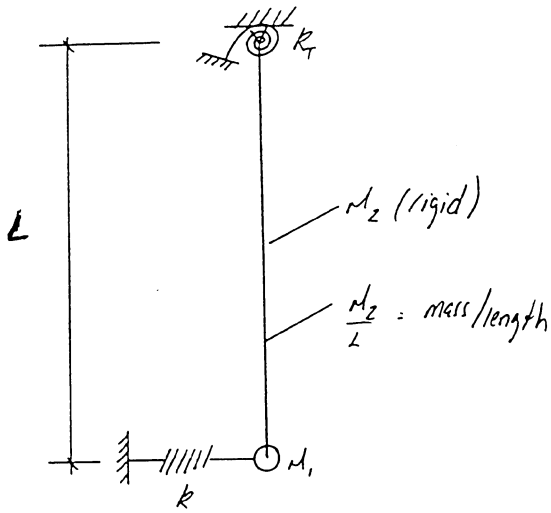

$$-M_1 s\theta - F_s L s\theta - F_s L s\theta - I \ddot{\theta} s\theta - M_1 g L ((1 - \cos(\theta + s\theta)) - (1 - \cos\theta)) - \int_0^L \frac{M_2}{L} g r ((1 - \cos(\theta + s\theta)) - (1 - \cos\theta)) dr = 0$$

$$-k_r \theta s\theta - kL^2 \theta s\theta - M_1 L \ddot{\theta} s\theta - \frac{M_2 L^2}{3} \ddot{\theta} s\theta - M_1 g L ((1 - \cos(\theta + s\theta)) - (1 - \cos\theta)) - \int_0^L \frac{M_2}{L} g r ((1 - \cos(\theta + s\theta)) - (1 - \cos\theta)) dr = 0$$

trigonometric Identities

$$x = (1 - \cos(\theta + s\theta)) - (1 - \cos\theta)$$

$$x = 1 - \cos(\theta + s\theta) - 1 + \cos\theta$$

$$x = \cos\theta - \cos(\theta + s\theta)$$

$$x = \cos\theta - (\cos\theta \cos s\theta - \sin\theta \sin s\theta)$$

$$x = \cos\theta - \cos\theta \cos s\theta + \sin\theta \sin s\theta$$

small displacements $\cos\theta = 1$

$$\cos s\theta = 1$$

$$\sin\theta = 0$$

$$\sin s\theta = s\theta$$

$$\text{so, } x = \theta s\theta$$

\therefore

$$k_r \theta s\theta + kL^2 \theta s\theta + M_1 L \ddot{\theta} s\theta + \frac{M_2 L^2}{3} \ddot{\theta} s\theta + M_1 g L \theta s\theta + \int_0^L \frac{M_2}{L} g r \theta s\theta dr = 0$$

$$\frac{M_2 g}{L} \theta s\theta \left| \frac{r^2}{2} \right|_0^L = \frac{M_2 g}{L} \theta s\theta \left(\frac{L^2}{2} \right) = \frac{M_2 g L}{2} \theta s\theta$$

2.14 Cont.

$$k_T \theta \delta \theta + kL^2 \theta \delta \theta + M_1 L^2 \ddot{\theta} \delta \theta + \frac{M_2 L^2}{3} \ddot{\theta} \delta \theta + M_1 g L \theta \delta \theta + \frac{M_2 g L}{2} \theta \delta \theta = 0$$

equation of motion:

$$\left(\frac{M_2 L^2}{3} + M_1 L^2 \right) \ddot{\theta} + \left(kL^2 + k_T + M_1 g L + \frac{M_2 g L}{2} \right) \theta = 0 \quad \underline{Ans}$$

natural frequency:

$$\omega = \sqrt{\frac{kL^2 + k_T + M_1 g L + \frac{M_2 g L}{2}}{\frac{M_2 L^2}{3} + M_1 L^2}} \quad \underline{Ans}$$

2.15

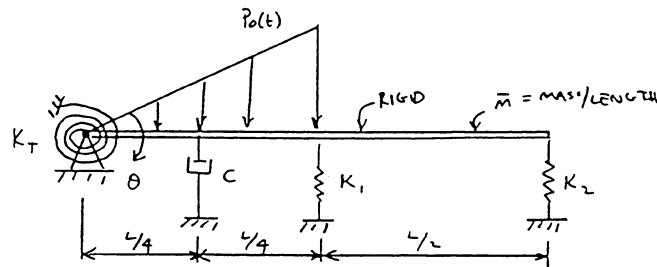

SOLUTION

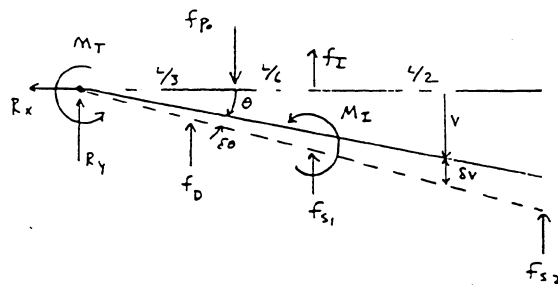

PRINCIPLE OF VIRTUAL DISPLACEMENTS

$$\delta W = 0$$

$$-f_{s1} \left(\frac{1}{2} \delta \theta \right) - f_{s2} (L \delta \theta) - f_D \left(\frac{1}{4} \delta \theta \right) - f_I \left(\frac{1}{2} \delta \theta \right) - M_I \delta \theta - M_T \delta \theta + f_{P_0} \left(\frac{1}{3} \delta \theta \right) = 0$$

FORCES

$$\begin{aligned} f_{s1} &= K_1 \left(\frac{1}{2} \theta \right) \\ f_{s2} &= K_2 (L \theta) \\ f_D &= c \left(\frac{1}{4} \dot{\theta} \right) \\ f_I &= (\bar{m} L) \left(\frac{1}{2} \ddot{\theta} \right) \end{aligned}$$

$$\begin{aligned} M_I &= I \ddot{\theta} = \frac{(\bar{m} L) L^2}{12} \ddot{\theta} \\ M_T &= K_T \theta \\ f_{P_0} &= \frac{P_0 L}{4} f(t) \end{aligned}$$

2.15 cont.

SUBSTITUTING INTO VIRTUAL WORK EQUATION:

$$-k_1 \frac{L^2}{4} \theta \delta\theta - k_2 L^2 \theta \delta\theta - c \frac{L^2}{16} \dot{\theta} \delta\theta - \bar{m} \frac{L^3}{4} \ddot{\theta} \delta\theta - \frac{\bar{m} L^3}{12} \ddot{\theta} \delta\theta - k_T \theta \delta\theta + \frac{P_0(t) L^2}{12} \delta\theta = 0$$

$$\left[\left(\frac{\bar{m} L^3}{4} + \frac{\bar{m} L^3}{12} \right) \ddot{\theta} + \left(\frac{c L^2}{16} \right) \dot{\theta} + \left(\frac{k_1 L^2}{4} + k_2 L^2 + k_T \right) \theta \right] \delta\theta = \frac{P_0(t) L^2}{12} \delta\theta$$

SINCE $\delta\theta \neq 0$

$$\left(\frac{\bar{m} L^3}{3} \right) \ddot{\theta} + \left(\frac{c L^2}{16} \right) \dot{\theta} + \left(\frac{k_1 L^2}{4} + k_2 L^2 + k_T \right) \theta = \frac{P_0(t) L^2}{12}$$

EQUATION OF MOTION

$$\omega = \sqrt{\frac{\frac{k_1 L^2}{4} + k_2 L^2 + k_T}{\frac{\bar{m} L^3}{3}}}$$

NATURAL FREQUENCY

2.16

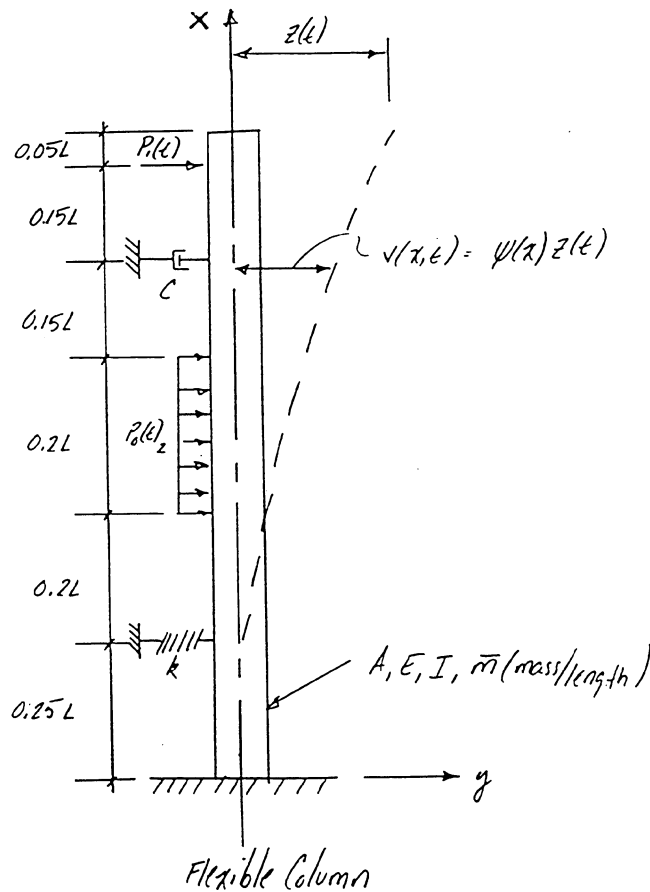

Assume deflected shape:

$$\psi(x) = \left(\frac{x}{L} \right)^2 \left(\frac{3}{2} - \frac{x}{2L} \right)$$

use the deflection @ the top of the structure as the generalized coordinate

2.16 cont.

Solution:

no concentrated mass = 0

$$\begin{aligned} m^* &= \int_0^L m(x) \psi^2(x) dx + \sum_i M_i \psi^2(x_i) \\ &= \bar{m} \int_0^L \left[\left(\frac{x}{L} \right)^2 \left(\frac{3}{2} - \frac{x}{2L} \right) \right]^2 dx \\ &= \bar{m} \int_0^L \frac{9x^4}{4L^4} - \frac{3x^5}{2L^5} + \frac{x^6}{4L^6} dx \\ &= \bar{m} \left[\frac{9x^5}{20L^4} - \frac{x^6}{4L^5} + \frac{x^7}{28L^6} \right]_0^L \\ &= \bar{m} \left(\frac{9L^5}{20L^4} - \frac{L^6}{4L^5} + \frac{L^7}{28L^6} \right) \end{aligned}$$

$$m^* = 0.23571 \bar{m} L$$

0 (no distrib. dampers)

$$c^* = \int_0^L c(x) \psi^2(x) dx + \sum_i c_i \psi^2(x_i)$$

$$\begin{aligned} &= c \left(\frac{9x_i^4}{4L^4} - \frac{3x_i^5}{2L^5} + \frac{x_i^6}{4L^6} \right) \quad \text{where } x_i = 0.8L \\ &= c \left(\frac{9(0.8L)^4}{4L^4} - \frac{3(0.8L)^5}{2L^5} + \frac{(0.8L)^6}{4L^6} \right) \end{aligned}$$

$$c^* = 0.49562 c$$

$$k^* = \int_0^L k(x) \psi^2(x) dx + \int EI(x) (\psi''(x))^2 dx + \sum_i k_i \psi^2(x_i)$$

no distributed stiffness = 0
spring

$$\psi(x) = \left(\frac{x}{L} \right)^2 \left(\frac{3}{2} - \frac{x}{2L} \right) = \frac{3x^2}{2L^2} - \frac{x^3}{2L^3}$$

$$\psi'(x) = \frac{3x}{L^2} - \frac{3x^2}{2L^3}$$

$$\psi''(x) = \frac{3}{L^2} - \frac{3x}{L^3}$$

2.16 Cont.

$$\begin{aligned}
 k^d &= EI \int_0^L \left(\frac{3}{L^2} - \frac{3x}{L^3} \right)^2 dx + k \left(\frac{9x_i^4}{4L^4} - \frac{3x_i^5}{2L^5} + \frac{x_i^6}{4L^6} \right) \\
 & \qquad \qquad \qquad \text{where } x_i = 0.25L \\
 &= EI \int_0^L \left(\frac{9}{L^4} - \frac{18x}{L^5} + \frac{9x^2}{L^6} \right) dx + k \left(\frac{9(0.25L)^4}{4L^4} - \frac{3(0.25L)^5}{2L^5} + \frac{(0.25L)^6}{4L^6} \right) \\
 &= EI \left[\frac{9x}{L^4} - \frac{9x^2}{L^5} + \frac{3x^3}{L^6} \right]_0^L + (0.00739 k) \\
 &= EI \left(\frac{9L}{L^4} - \frac{9L^2}{L^5} + \frac{3L^3}{L^6} \right) + (0.00739 k) \\
 &= EI \left(\frac{9}{L^3} - \frac{9}{L^3} + \frac{3}{L^3} \right) + (0.00739 k)
 \end{aligned}$$

$$\boxed{k^d = \frac{3EI}{L^3} + 0.00739 k}$$

$$\begin{aligned}
 p^*(t) &= \int p(x,t) \psi(x) dx + \sum_i P_i \psi(x_i) \\
 &= P_0 \int_{0.45L}^{0.65L} \left(\frac{3x^2}{2L^2} - \frac{x^3}{2L^3} \right) dx + P_1 \left(\frac{3x_i^2}{2L^2} - \frac{x_i^3}{2L^3} \right) \\
 & \qquad \qquad \qquad \text{where } x_i = 0.95L \\
 &= P_0 \left[\frac{x^3}{2L^2} - \frac{x^4}{8L^3} \right]_{0.45L}^{0.65L} + P_1 \left(\frac{3(0.95L)^2}{2L^2} - \frac{(0.95L)^3}{2L^3} \right) \\
 &= P_0 \left(\frac{(0.65L)^3}{2L^2} - \frac{(0.65L)^4}{8L^3} - \frac{(0.45L)^3}{2L^2} + \frac{(0.45L)^4}{8L^3} \right) + (0.92506 P_1)
 \end{aligned}$$

$$\boxed{p^*(t) = 0.07456 P_0 L + 0.92506 P_1}$$

2.16 Cont.

natural frequency:

$$m^* \ddot{z} + c^* \dot{z} + k^* z = p^*(t)$$

equation of motion \rightarrow

$$(0.23571 \bar{m} L) \ddot{z} + (0.49522 c) \dot{z} + \left(\frac{3EI}{L^3} + 0.00739 k \right) z = 0.07456 P_0 L + 0.92506 P_0$$

$$\omega = \sqrt{\frac{\frac{3EI}{L^3} + 0.00739 k}{0.23571 \bar{m} L}} \quad \text{Ans}$$

find critical load N_{cr}

$$k_{cr}^* = N_{cr} \int (\psi'(x))^2 dx$$

$$= N_{cr} \int_0^L \left(\frac{3x}{L^2} - \frac{3x^2}{2L^3} \right)^2 dx$$

$$= N_{cr} \int_0^L \left(\frac{9x^2}{L^4} - \frac{9x^3}{L^5} + \frac{9x^4}{4L^6} \right) dx$$

$$= N_{cr} \left[\frac{3x^3}{L^4} - \frac{9x^4}{4L^5} + \frac{9x^5}{20L^6} \right]_0^L$$

$$= N_{cr} \left(\frac{3L^3}{L^4} - \frac{9L^4}{4L^5} + \frac{9L^5}{20L^6} \right)$$

$$k_{cr}^* = N_{cr} \left(\frac{1.2}{L} \right) = \frac{1.2 N_{cr}}{L} \quad \text{Ans}$$

$$k^* - k_{cr}^* = \frac{3EI}{L^3} + 0.00739 k - \frac{1.2 N_{cr}}{L} = 0$$

2.16 Cont.

$$\frac{1.2 N_{cr}}{L} = \frac{3EI}{L^3} + 0.00739 k$$

$$N_{cr} = \left(\frac{3EI}{L^3} + 0.00739 k \right) \left(\frac{L}{1.2} \right)$$

$$N_{cr} = \frac{2.5EI}{L^2} + 0.00616 kL \quad \text{ANS}$$

2.17

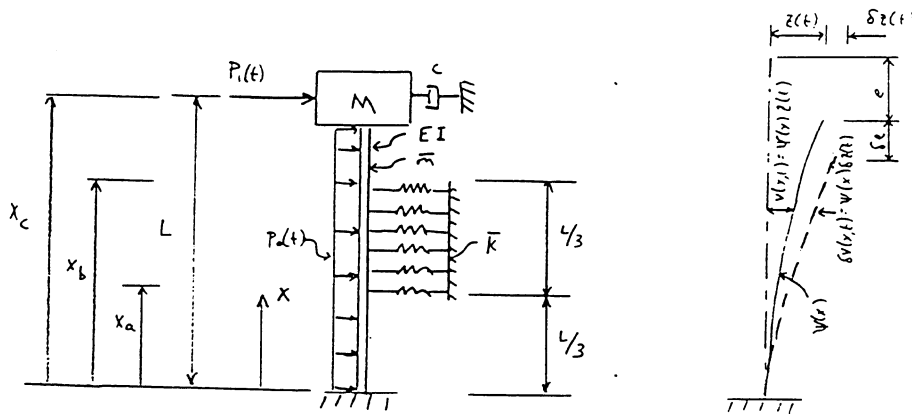

SOLUTION

CHECK BOUNDARY CONDITIONS

$$v(0,t) = v'(0,t) = 0$$

$$\psi(x) = \frac{3x^2}{L^2} - \frac{x^3}{L^3} \rightarrow \psi(0) = 0$$

$$\psi'(x) = \frac{6x}{L^2} - \frac{3x^2}{L^3} \rightarrow \psi'(0) = 0$$

ALL KINEMATIC BOUNDARY CONDITIONS SATISFIED.

HELPFUL RELATIONSHIPS IN COMPUTING VIRTUAL WORK EXPRESSIONS

$$v'(x,t) = \psi'(x) z(t) \quad \delta v(x,t) = \psi(x) \delta z(t)$$

$$v''(x,t) = \psi''(x) z(t) \quad \delta v'(x,t) = \psi'(x) \delta z(t)$$

$$\dot{v}(x,t) = \dot{\psi}(x) z(t) \quad \delta \dot{v}(x,t) = \dot{\psi}(x) \delta z(t)$$

$$\ddot{v}(x,t) = \ddot{\psi}(x) z(t) \quad \delta \ddot{v}(x,t) = \ddot{\psi}(x) \delta z(t)$$

INERTIA

$$\delta W_{INERTIA} = - \int_0^L \bar{m} \ddot{v}(x,t) \delta v(x,t) dx - M \ddot{v}(x_c,t) \delta v(x_c,t)$$

$$= - \left[\int_0^L \bar{m} \psi(x)^2 dx + M \psi(x_c)^2 \right] \ddot{z} \delta z$$

DAMPING

$$\delta W_{DAMPING} = - c \dot{v}(x_c,t) \delta v(x_c,t)$$

$$= - c \psi(x_c)^2 \dot{z} \delta z$$

TRANSVERSE LOADS

$$\delta W_P = \int_0^L P_2(x,t) \delta v(x,t) dx + P_1(t) \delta v(x_c,t)$$

$$= \left[\int_0^L P_2(x,t) \psi(x) dx + P_1(t) \psi(x_c) \right] \delta z$$

2.17 Cont.

AXIAL LOAD

$$\delta W_N = N \delta e$$

$$e = \frac{1}{2} \int_0^L (x')^2 dx \quad \text{AND} \quad \delta e = \frac{1}{2} \int_0^L v' \delta v' dx$$

$$\delta W_N = \int_0^L N [\psi'(x)]^2 dx \quad z \delta z$$

SPRINGS

$$\begin{aligned} \delta W_{\text{SPRING}} &= - \int_{x_a}^{x_b} \bar{k} v(x,t) \delta v(x,t) dx \\ &= - \left[\int_{x_a}^{x_b} E v(x)^2 dx \right] z \delta z \end{aligned}$$

BENDING

$$\begin{aligned} \delta W_{\text{BENDING}} &= - \int_0^L EI(x) v''(x,t) \delta v''(x,t) dx \\ &= - \left[\int_0^L EI(x) [\psi''(x)]^2 dx \right] z \delta z \end{aligned}$$

VIRTUAL WORK EQUATION

$$\delta W = 0$$

$$\begin{aligned} & - \left[\int_0^L \bar{m} v(x)^2 dx + M \psi(x_c)^2 \right] \ddot{z} \delta z - \left[c \psi(x_c)^2 \right] \dot{z} \delta z - \left[\int_{x_a}^{x_b} \bar{k} v(x)^2 dx + \int_0^L EI(x) [\psi''(x)]^2 dx \right] z \delta z \\ & + \left[\int_0^L N [\psi'(x)]^2 dx \right] z \delta z + \left[\int_0^L p_0(x,t) \psi(x) dx + P_1(t) \psi(x_c) \right] \delta z = 0 \end{aligned}$$

REARRANGING:

$$\begin{aligned} & \left[\int_0^L \bar{m} v(x)^2 dx + M \psi(x_c)^2 \right] \ddot{z} \delta z + \left[c \psi(x_c)^2 \right] \dot{z} \delta z + \left[\int_{x_a}^{x_b} \bar{k} v(x)^2 dx + \int_0^L EI(x) [\psi''(x)]^2 dx \right. \\ & \left. - \int_0^L N [\psi'(x)]^2 dx \right] z \delta z - \left[\int_0^L p_0(x,t) \psi(x) dx + P_1(t) \psi(x_c) \right] \delta z = 0 \end{aligned}$$

SIMPLIFYING THE FORM

$$\left[m^* \ddot{z} + c^* \dot{z} + k^* z - k_G^* z - p^*(t) \right] \delta z = 0$$

SINCE $\delta z \neq 0$

$$m^* \ddot{z} + c^* \dot{z} + (k^* - k_G^*) z = p^*(t)$$

GENERALIZED PARAMETERS

$$\begin{aligned} m^* &= \int_0^L \bar{m} v(x)^2 dx + M \psi(x_c)^2 \\ &= \bar{m} \int_0^L \left(3\left(\frac{x}{L}\right)^2 - \left(\frac{x}{L}\right)^3 \right)^2 dx + M \left[3\left(\frac{x_c}{L}\right)^2 - \left(\frac{x_c}{L}\right)^3 \right]^2 \\ &= \bar{m} \int_0^L \left[9\frac{x^4}{L^4} - 2(3)\left(\frac{x^2}{L^2}\right)\left(\frac{x^3}{L^3}\right) + \frac{x^6}{L^6} \right] dx + M [3(1) - 1]^2 \\ &= \bar{m} \int_0^L \left(\frac{9}{L^4} x^4 - \frac{6}{L^5} x^5 + \frac{x^6}{L^6} \right) dx + M(4) \\ &= \bar{m} \left[\frac{9}{5L^4} x^5 - \frac{x^6}{L^6} + \frac{x^7}{7L^6} \right]_0^L + 4M \\ &= \bar{m} \left(\frac{9L^5}{5L^4} - 1 + \frac{L^7}{7L^6} \right) + 4M \\ &= \bar{m} \left(\frac{9}{5}L - 1 + \frac{L}{7} \right) + 4M \\ &= 1.943 \bar{m} L - \bar{m} + 4M \end{aligned}$$

2.17 cont.

$$\begin{aligned}
 c^* &= c \psi(x_c)^2 \\
 &= c \left[3 \left(\frac{x_c}{L} \right)^2 - \left(\frac{x_c}{L} \right)^3 \right]^2 \\
 &= c \left[3 \left(\frac{L}{2} \right)^2 - \left(\frac{L}{2} \right)^3 \right]^2 \\
 &= 4c
 \end{aligned}$$

$$\begin{aligned}
 K^* &= \int_{x_a}^{x_b} \bar{k} \psi(x)^2 dx + \int_0^L EI(x) [\psi''(x)]^2 dx \\
 &= \bar{k} \int_{L/3}^{2L/3} \left(\frac{9}{L^4} x^4 - \frac{6}{L^3} x^3 + \frac{x^6}{L^6} \right) dx + EI \int_0^L \left[\frac{6}{L^2} - \frac{6x}{L^3} \right]^2 dx \\
 &= \bar{k} \left[\frac{9x^5}{5L^4} - \frac{x^6}{L^3} + \frac{x^7}{7L^6} \right]_{L/3}^{2L/3} + EI \int_0^L \left(\frac{36}{L^4} - \frac{72x}{L^5} + \frac{36x^2}{L^6} \right) dx \\
 &= \bar{k} \left[\left[\frac{9}{5L^4} \left(\frac{2L}{3} \right)^5 - \frac{1}{L^3} \left(\frac{2L}{3} \right)^6 + \frac{1}{7L^6} \left(\frac{2L}{3} \right)^7 \right] - \left[\frac{9}{5L^4} \left(\frac{L}{3} \right)^5 - \frac{1}{L^3} \left(\frac{L}{3} \right)^6 + \frac{1}{7L^6} \left(\frac{L}{3} \right)^7 \right] \right] \\
 &\quad + EI \left[\frac{36x}{L^4} - \frac{36x^2}{L^5} + \frac{12x^3}{L^6} \right]_0^L \\
 &= \bar{k} \left[(0.2370L - 0.08779 + 0.008361L) - (0.007407L - 0.001372 + 6.532 \times 10^{-5}L) \right] \\
 &\quad + EI \left(\frac{36}{L^3} - \frac{36}{L^5} + \frac{12}{L^6} \right) \\
 &= 12 \frac{EI}{L^3} + (0.2379L - 0.08642) \bar{k}
 \end{aligned}$$

$$K_G^* = N \int_0^L [\psi'(x)]^2 dx = 0 \quad \text{SINCE } N=0 \quad (\text{NEGLECTING SELF-WEIGHT})$$

$$\begin{aligned}
 P^*(t) &= \int_0^L p_0(x,t) \psi(x) dx + P_1(t) \psi(x_c) \\
 &= P_0 \int_0^L \left(\frac{3x^2}{L^2} - \frac{x^3}{L^3} \right) dx + P_1(t) \left[3 \left(\frac{x_c}{L} \right)^2 - \left(\frac{x_c}{L} \right)^3 \right] \\
 &= P_0 \left[\frac{x^3}{L^2} - \frac{x^4}{4L^3} \right]_0^L + P_1(t) [3 - 1] \\
 &= P_0 \left[L - \frac{L}{4} \right] + 2P_1(t) \\
 &= 0.75 P_0(t) L + 2P_1(t)
 \end{aligned}$$

EQUATION OF MOTION

$$\begin{aligned}
 [1.943 \bar{m} L - \bar{m} + 4M] \ddot{z} + [4c] \dot{z} + \left[12 \frac{EI}{L^3} + 0.2379L \bar{k} - 0.08642 \bar{k} \right] z \\
 = 0.75 P_0(t) L + 2P_1(t)
 \end{aligned}$$

NATURAL FREQUENCY

$$\omega = \sqrt{\frac{k^* - k_G^*}{m^*}} = \sqrt{\frac{12 \frac{EI}{L^3} + 0.2379L \bar{k} - 0.08642 \bar{k}}{1.943 \bar{m} L - \bar{m} + 4M}} \quad \text{RAD/SEC}$$

2.17 Cont.

DOWNWARD LOAD N APPLIED:

$$\begin{aligned}K_G^* &= N \int_0^L [\psi'(x)]^2 dx \\&= N \int_0^L \left(\frac{36}{L^4} x^2 - \frac{36}{L^3} x^3 + \frac{9}{L^2} x^4 \right) dx \\&= N \left[\frac{12}{L} - \frac{9}{L} + \frac{9}{5L} \right] \\&= 4.8 \frac{N}{L}\end{aligned}$$

CALCULATE COMBINED STIFFNESS:

$$K^* - K_G^* = 12 \frac{EI}{L^3} + 0.2379 L \bar{K} - 0.08642 \bar{K} - 4.8 \frac{N}{L}$$

CALCULATE N_{CR} :

$$K^* - K_{CR}^* = 0$$

$$12 \frac{EI}{L^3} + 0.2379 L \bar{K} - 0.08642 \bar{K} - 4.8 \frac{N_{CR}}{L} = 0$$

$$N_{CR} = 2.5 \frac{EI}{L^2} + 0.04956 \bar{K} L^2 - 1.80 \times 10^{-2} \bar{K} L$$

2.18

$$\phi(x) = \frac{x^2}{L^2}$$

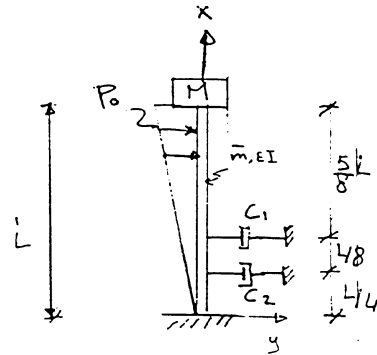

$$M^* = \int_0^L \bar{m} \phi^2(x) dx + M [\phi(x)]^2 \Big|_{x=L}$$

$$= \bar{m} \int_0^L \frac{x^4}{L^4} dx + M$$

$$= \bar{m} \frac{x^5}{5 L^4} \Big|_0^L + M$$

$$\boxed{M^* = \frac{\bar{m} L}{5} + M}$$

2.18 Cont.

$$C^* = C_1 [\phi(x)]^2 \Big|_{x=\frac{3}{8}L} + C_2 [\phi(x)]^2 \Big|_{x=\frac{L}{4}}$$

$$= C_1 \frac{x^4}{L^4} \Big|_{x=\frac{3}{8}L} + C_2 \frac{x^4}{L^4} \Big|_{x=\frac{L}{4}}$$

$$C^* = \frac{81}{4096} C_1 + \frac{1}{256} C_2$$

$$K^* = \int_0^L EI [\phi''(x)]^2 dx$$

$$\phi(x) = \frac{x^2}{L^2} \quad \phi'' = \frac{2}{L^2} \quad [\phi'']^2 = \frac{4}{L^4}$$

$$K^* = EI \int_0^L \frac{4}{L^4} dx = 4 \frac{EI}{L^4} x \Big|_0^L = \frac{4EI}{L^3}$$

note compare with cantilever $K^* = \frac{3EI}{L^3}$ this is, because $\phi(x)$ is not necessarily to describe the deformed shape (i.e. ϕ'' is constant for the whole beam)

$$F^*(t) = \int_0^L \frac{P_0 x}{L} f(t) \frac{x^2}{L^2} dx$$

$$= \frac{P_0 f(t)}{L^3} \int_0^L x^3 dx = \frac{P_0 f(t)}{L^3} \left[\frac{x^4}{4} \right]_0^L$$

$$= \frac{P_0 L}{4} f(t)$$

$$K_g^* = N \int_0^L \left(\frac{2x}{L^2} \right)^2 dx$$

$$= N \int_0^L \frac{4x^2}{L^4} dx = \frac{4N}{L^4} \left[\frac{x^3}{3} \right]_0^L$$

$$K_g^* = \frac{4}{3} \frac{N}{L}$$

$$K^* = K^* - K_g^* = \frac{4EI}{L^3} - \frac{4}{3} \frac{N}{L}$$

2.18 Cont.

for buckling load $\bar{K} = 0$

$$\frac{4EI}{L^3} = \frac{4}{3} \frac{N_{cr}}{L}$$

$$N_{cr} = \frac{3EI}{L^2}$$

Note:1 For cantilever beam $N_{cr} = \frac{\pi^2 EI}{4L^2} = 2.46 \frac{EI}{L^2}$

Note:2 if we consider the o.w of the beam & M at the top end K_G is equals to:

$$\begin{aligned} K_G &= \int_0^L [Mg + \bar{m}g(L-x) + N] \frac{4x^2}{L^4} dx \\ &= \frac{4}{3} \left(\frac{N+Mg}{L} + \bar{m}g \right) - \int_0^L \bar{m}g \frac{4x^3}{L^4} dx \\ &= \frac{4}{3} \left(\frac{N+Mg}{L} + \bar{m}g \right) - \bar{m}g \\ &= \frac{4}{3} \frac{N}{L} + \frac{4}{3} \frac{Mg}{L} + \frac{\bar{m}g}{3} \end{aligned}$$

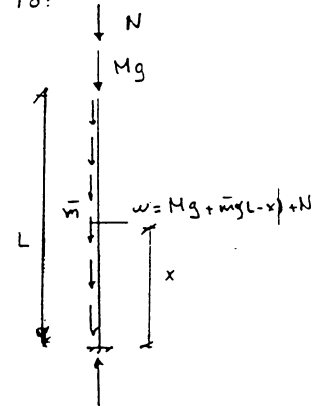

$$\frac{4}{3} \frac{N}{L} + \frac{4}{3} \frac{Mg}{L} + \frac{\bar{m}g}{3} = \frac{4EI}{L^3}$$

$$\frac{4}{3} \frac{N}{L} = \frac{4EI}{L^3} - \frac{4Mg}{3L} - \frac{\bar{m}g}{3}$$

$$N_{cr} = \frac{3EI}{L^2} - Mg - \frac{\bar{m}gL}{4}$$

2.19

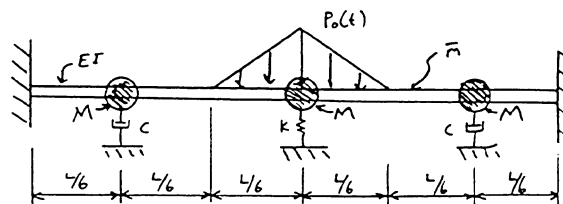

2.19 cont.

SOLUTION

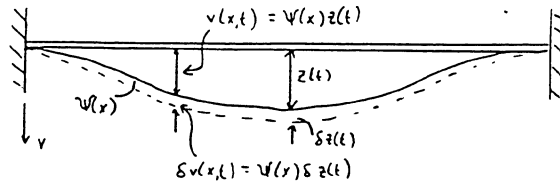

CHECK BOUNDARY CONDITIONS

$$v(0,t) = v(L,t) = v'(0,t) = v'(L,t) = 0$$

$$\psi(x) = \frac{16x^2}{L^2} - \frac{32x^3}{L^3} + \frac{16x^4}{L^4}$$

$$\psi(0) = 0 \quad \psi(L) = 16 - 32 + 16 = 0$$

$$\psi'(x) = \frac{32x}{L^2} - \frac{96x^2}{L^3} + \frac{64x^3}{L^4}$$

$$\psi'(0) = 0 \quad \psi'(L) = \frac{32}{L} - \frac{96}{L} + \frac{64}{L} = 0$$

$$\psi'(\frac{L}{2}) = \frac{16}{L} - \frac{24}{L} + \frac{8}{L} = 0$$

EVALUATE THE GENERALIZED PARAMETERS

$$\begin{aligned} \text{MASS } m^* &= \bar{m} \int_0^L \psi(x)^2 dx + M \psi^2(\frac{L}{6}) + M \psi^2(\frac{L}{2}) + M \psi^2(\frac{5L}{6}) \\ &= \bar{m} \int_0^L \left[\frac{256x^4}{L^4} - \frac{1024x^5}{L^5} + \frac{1536x^6}{L^6} - \frac{1024x^7}{L^7} + \frac{256x^8}{L^8} \right] dx \\ &\quad + 256M \left[\frac{(\frac{L}{6})^4}{L^4} - \frac{4(\frac{L}{6})^5}{L^5} + \frac{6(\frac{L}{6})^6}{L^6} - \frac{4(\frac{L}{6})^7}{L^7} + \frac{(\frac{L}{6})^8}{L^8} \right] \\ &\quad + 256M \left[\frac{(\frac{L}{2})^4}{L^4} - \frac{4(\frac{L}{2})^5}{L^5} + \frac{6(\frac{L}{2})^6}{L^6} - \frac{4(\frac{L}{2})^7}{L^7} + \frac{(\frac{L}{2})^8}{L^8} \right] \\ &\quad + 256M \left[\frac{(\frac{5L}{6})^4}{L^4} - \frac{4(\frac{5L}{6})^5}{L^5} + \frac{6(\frac{5L}{6})^6}{L^6} - \frac{4(\frac{5L}{6})^7}{L^7} + \frac{(\frac{5L}{6})^8}{L^8} \right] \end{aligned}$$

$$m^* = 0.40635 \bar{m} L + 1.1905 M$$

$$\begin{aligned} \text{DAMPING } c^* &= c \psi^2(\frac{L}{6}) + c \psi^2(\frac{5L}{6}) \\ &= 256c \left[\frac{(\frac{L}{6})^4}{L^4} - \frac{4(\frac{L}{6})^5}{L^5} + \frac{6(\frac{L}{6})^6}{L^6} - \frac{4(\frac{L}{6})^7}{L^7} + \frac{(\frac{L}{6})^8}{L^8} \right] \\ &\quad + 256c \left[\frac{(\frac{5L}{6})^4}{L^4} - \frac{4(\frac{5L}{6})^5}{L^5} + \frac{6(\frac{5L}{6})^6}{L^6} - \frac{4(\frac{5L}{6})^7}{L^7} + \frac{(\frac{5L}{6})^8}{L^8} \right] \\ &= 0.1905 c \end{aligned}$$

$$\begin{aligned} \text{STIFFNESS } k^* &= \int_0^L EI(x) [\psi''(x)]^2 dx + K \psi^2(\frac{L}{2}) \\ &= \int_0^L EI(x) \left[\frac{32}{L^2} - \frac{192x}{L^3} + \frac{192x^2}{L^4} \right]^2 dx + 256K \left[\frac{(\frac{L}{2})^4}{L^4} - \frac{4(\frac{L}{2})^5}{L^5} + \frac{6(\frac{L}{2})^6}{L^6} - \frac{4(\frac{L}{2})^7}{L^7} + \frac{(\frac{L}{2})^8}{L^8} \right] \\ &= EI \int_0^L \left(\frac{1024}{L^4} - \frac{12288x}{L^5} + \frac{49152x^2}{L^6} - \frac{73728x^3}{L^7} + \frac{36864x^4}{L^8} \right) dx + K(1) \\ &= EI \left[\frac{1024}{L^3} - \frac{12288}{2L^4} + \frac{49152}{3L^3} - \frac{73728}{4L^3} + \frac{36864}{5L^3} \right] + K \\ &= 204.8 \frac{EI}{L^3} + K \end{aligned}$$

2.19 Cont.

$$\begin{aligned}
 \text{FORCE } P^*(t) &= \int_{1/3}^{1/2} (6P_0 \frac{x}{L} - 2P_0) \psi(x) dx + \int_{1/2}^{2/3} (-6P_0 \frac{x}{L} + 4P_0) \psi(x) dx \\
 &= 2P_0 \left[\int_{1/3}^{1/2} (3\frac{x}{L} - 1) \left(\frac{16x^2}{L^2} - \frac{32x^3}{L^3} + \frac{16x^4}{L^4} \right) dx + \int_{1/2}^{2/3} (-3\frac{x}{L} + 2) \left(\frac{16x^2}{L^2} - \frac{32x^3}{L^3} + \frac{16x^4}{L^4} \right) dx \right] \\
 &= 2P_0 \left[\int_{1/3}^{1/2} \left(-\frac{16x^2}{L^2} + \frac{80x^3}{L^3} - \frac{112x^4}{L^4} + \frac{48x^5}{L^5} \right) dx + \int_{1/2}^{2/3} \left(\frac{32x^2}{L^2} - \frac{112x^3}{L^3} + \frac{128x^4}{L^4} - \frac{48x^5}{L^5} \right) dx \right] \\
 &= 2P_0 \left(\left[-\frac{16x^3}{3L^2} + \frac{20x^4}{L^3} - \frac{112x^5}{5L^4} + \frac{8x^6}{L^5} \right]_{1/3}^{1/2} + \left[\frac{32x^3}{3L^2} - \frac{28x^4}{L^3} + \frac{128x^5}{5L^4} - \frac{8x^6}{L^5} \right]_{1/2}^{2/3} \right) \\
 &= 2P_0 \left(\frac{16(\frac{1}{2})^3}{3L^2} + \frac{20(\frac{1}{2})^4}{L^3} - \frac{112(\frac{1}{2})^5}{5L^4} + \frac{8(\frac{1}{2})^6}{L^5} + \frac{16(\frac{2}{3})^3}{3L^2} - \frac{20(\frac{2}{3})^4}{L^3} + \frac{112(\frac{2}{3})^5}{5L^4} - \frac{8(\frac{2}{3})^6}{L^5} \right. \\
 &\quad \left. + \frac{32(\frac{2}{3})^3}{3L^2} - \frac{28(\frac{2}{3})^4}{L^3} + \frac{128(\frac{2}{3})^5}{5L^4} - \frac{8(\frac{2}{3})^6}{L^5} - \frac{32(\frac{1}{2})^3}{3L^2} + \frac{28(\frac{1}{2})^4}{L^3} - \frac{128(\frac{1}{2})^5}{5L^4} + \frac{8(\frac{1}{2})^6}{L^5} \right) \\
 &= 6.7069 P_0(t) L
 \end{aligned}$$

EQUATION OF MOTION

$$(0.40635 \bar{m} L + 1.1905 M) \ddot{z} + (0.1905 c) \dot{z} + \left(204.8 \frac{EI}{L^3} + k \right) z = 6.7069 P_0(t) L$$

NATURAL FREQUENCY

$$\omega = \sqrt{\frac{204.8 \frac{EI}{L^3} + k}{0.40635 \bar{m} L + 1.1905 M}}$$

GENERALIZED GEOMETRIC STIFFNESS

$$\begin{aligned}
 K_G^* &= N \int_0^L [\psi'(x)]^2 dx \\
 &= N \int_0^L \left(32 \frac{x}{L} - 96 \frac{x^2}{L^2} + 64 \frac{x^3}{L^3} \right)^2 dx \\
 &= 1024 N \int_0^L \left(\frac{x^2}{L^4} - \frac{6x^3}{L^5} + \frac{13x^4}{L^6} - \frac{12x^5}{L^7} + \frac{4x^6}{L^8} \right) dx \\
 &= 1024 N \left[\frac{1}{3L} - \frac{6}{4L} + \frac{13}{5L} - \frac{2}{L} + \frac{4}{7L} \right] \\
 &= 4.8762 \frac{N}{L}
 \end{aligned}$$

COMBINED STIFFNESS

$$K^* - K_G^* = 204.8 \frac{EI}{L^3} + k - 4.8762 \frac{N}{L}$$

CRITICAL BUCKLING LOAD, N_{CR}

$$\begin{aligned}
 K^* - K_C^* &= 0 \\
 204.8 \frac{EI}{L^3} + k - 4.8762 \frac{N_{CR}}{L} &= 0
 \end{aligned}$$

$$N_{CR} = 42 \frac{EI}{L^2} + 0.20508 k L$$

2.20

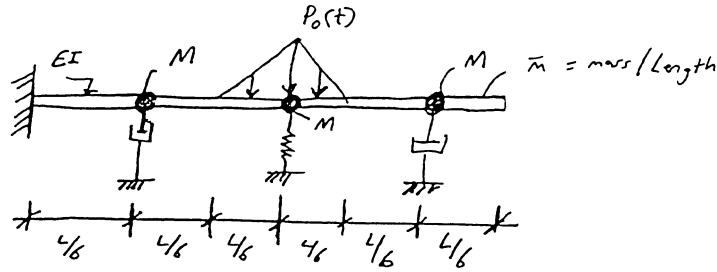

$$\psi(x) = 3\left(\frac{x}{L}\right)^2 - \left(\frac{x}{L}\right)^3$$

Use deflection at the free end as the generalized coordinate

SOLUTION:

$$\psi(x) = \frac{3x^2}{L^2} - \frac{x^3}{L^3}$$

$$[\psi(x)]^2 = \frac{9x^4}{L^4} - \frac{6x^5}{L^5} + \frac{x^6}{L^6}$$

$$\psi'(x) = \frac{6x}{L^2} - \frac{3x^2}{L^3}$$

$$[\psi'(x)]^2 = \frac{36x^2}{L^4} - \frac{36x^3}{L^5} + \frac{9x^4}{L^6}$$

$$\psi''(x) = \frac{6}{L^2} - \frac{6x}{L^3}$$

$$[\psi''(x)]^2 = \frac{36}{L^4} - \frac{72x}{L^5} + \frac{36x^2}{L^6}$$

$$m^* = \int_0^L m(x) \psi^2(x) dx + \sum M_i \psi^2(x_i)$$

$$m^* = \bar{m} \int_0^L \left(\frac{9x^4}{L^4} - \frac{6x^5}{L^5} + \frac{x^6}{L^6} \right) dx + M \left[\frac{9x^4}{L^4} - \frac{6x^5}{L^5} + \frac{x^6}{L^6} \right]_{4/6}^{4/6}$$

$$m^* = \bar{m} \left[\frac{9x^5}{5L^4} - \frac{x^6}{L^5} + \frac{x^7}{7L^6} \right]_0^L + M \left[\frac{9(\frac{L}{6})^4}{L^4} - \frac{6(\frac{L}{6})^5}{L^5} + \frac{(\frac{L}{6})^6}{L^6} \right] \\ + M \left[\frac{9(\frac{L}{6})^4}{L^4} - \frac{6(\frac{L}{6})^5}{L^5} + \frac{(\frac{L}{6})^6}{L^6} \right] \\ + M \left[\frac{9(\frac{5L}{6})^4}{L^4} - \frac{6(\frac{5L}{6})^5}{L^5} + \frac{(\frac{5L}{6})^6}{L^6} \right]$$

$$m^* = .943 \bar{m} L + 2.66 M$$

$$c^* = \sum c \psi^2(x) = c \left[\frac{9x^4}{L^4} - \frac{6x^5}{L^5} + \frac{x^6}{L^6} \right]_{4/6}^{4/6}$$

$$= c \left[\frac{9(\frac{L}{6})^4}{L^4} - \frac{6(\frac{L}{6})^5}{L^5} + \frac{(\frac{L}{6})^6}{L^6} \right] \\ + c \left[\frac{9(\frac{5L}{6})^4}{L^4} - \frac{6(\frac{5L}{6})^5}{L^5} + \frac{(\frac{5L}{6})^6}{L^6} \right]$$

$$c^* = 2.27 c$$

2.20 cont.

$$\begin{aligned}
 K^* &= \int EI(\kappa) [\psi''(x)]^2 dx + \sum K_i \psi^2(x_i) \\
 &= EI \int_0^L \left(\frac{36}{L^4} - \frac{72x}{L^5} + \frac{36x^2}{L^6} \right) dx + K \left[\frac{9x^4}{L^4} - \frac{6x^5}{L^5} + \frac{x^6}{L^6} \right]_{L/2}^{L/2} \\
 &= EI \left[\frac{36x}{L^4} - \frac{72x^2}{2L^5} + \frac{36x^3}{3L^6} \right]_0^L + K \left[\frac{9(\frac{L}{2})^4}{L^4} - \frac{6(\frac{L}{2})^5}{L^5} + \frac{(\frac{L}{2})^6}{L^6} \right] \\
 &= EI \left[\frac{36}{L^3} - \frac{36}{L^3} + \frac{12}{L^3} \right] + K (1.391)
 \end{aligned}$$

$$K^* = \frac{12EI}{L^3} + .391K$$

$$\begin{aligned}
 p^*(t) &= \int p(x,t) \psi(x) dx + \sum p_i \psi(x_i) \\
 &= \int_{L/3}^{2L/3} p_0(t) \left[\frac{3x^2}{L^2} - \frac{x^4}{L^3} \right] dx \\
 &= p_0 \left[\frac{x^3}{L^2} - \frac{x^5}{4L^3} \right]_{L/3}^{2L/3} \\
 &= p_0 \left[\left(\frac{(2L/3)^3}{L^2} - \frac{(2L/3)^5}{4L^3} \right) - \left(\frac{(L/3)^3}{L^2} - \frac{(L/3)^5}{4L^3} \right) \right]
 \end{aligned}$$

$$p^*(t) = .213 p_0 L$$

Eq. of Motion

$$(.943 \bar{m}L + 2.66M) \ddot{z} + (2.27C) \dot{z} + \left(\frac{12EI}{L^3} + .391K \right) z = .213 p_0 L$$

Natural Frequency

$$\omega = \sqrt{\frac{K^*}{m^*}} = \sqrt{\frac{\left(\frac{12EI}{L^3} \right) + .391K}{.943 \bar{m}L + 2.66M}}$$

$$\begin{aligned}
 K_G^* &= N \int (\psi'(x))^2 dx \\
 &= N \int_0^L \left[\frac{36x^2}{L^4} - \frac{36x^3}{L^5} + \frac{9x^4}{L^6} \right] dx \\
 &= N \left[\frac{12x^3}{L^4} - \frac{9x^4}{L^5} + \frac{9x^5}{5L^6} \right]_0^L \\
 &= N \left[\frac{12}{L} - \frac{9}{L} + \frac{1.8}{L} \right] \Rightarrow K_G^* = 4.8 \frac{N}{L}
 \end{aligned}$$

2.20 Cont.

Combined Stiffness

$$K^* - KG^* = \frac{12EI}{L^3} + .391K - \frac{4.8N_{cr}}{L} = 0$$

$$N_{cr} = 2.5 \frac{EI}{L^2} + .08145 KL$$

3.1

$$\text{mass} = (50 \text{ lb weight}) \left(\frac{1}{32.2 \frac{\text{ft}}{\text{sec}^2}} \right) = 1.553 \text{ lb sec}^2/\text{ft} \text{ or } 0.1294 \text{ lb sec}^2/\text{in}$$

$$\omega = \sqrt{\frac{k}{m}} = \left(\frac{10 \text{ lb/in}}{0.1294 \text{ lb sec}^2/\text{in}} \right)^{1/2} = 8.791 \text{ rad/sec}$$

$$f = \frac{\omega}{2\pi} = \frac{8.791 \text{ rad/sec}}{2\pi} = 1.399 \text{ cps}$$

3.2

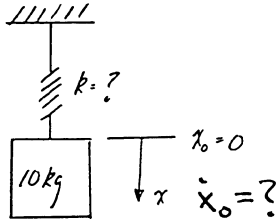

$$T (\text{period}) = 0.2 \text{ sec}$$

$$x (\text{amplitude}) = 60 \text{ mm}$$

a) find the spring constant k

$$T = \frac{2\pi}{\omega} = \frac{2\pi}{\left(\frac{k}{m}\right)^{1/2}}$$

$$0.2 \text{ sec} = \frac{2\pi}{\left(\frac{k}{10 \text{ kg}}\right)^{1/2}}$$

$$0.2 \text{ sec} = \frac{2\pi (10 \text{ kg})^{1/2}}{k^{1/2}}$$

$$k = \left(\frac{2\pi (10 \text{ kg})^{1/2}}{0.2 \text{ sec}} \right)^2 = 9869.6 \text{ kg/sec}^2 = \left(\frac{\text{N sec}^2/\text{m}}{1 \text{ kg}} \right) = 9869.6 \text{ N/m}$$

$$1 \text{ N} = 1 \text{ kg m/sec}^2$$

$$1 \text{ kg} = 1 \text{ N sec}^2/\text{m}$$

3.2 Cont.

b) find initial velocity \dot{x}_0
 $x = \left(x_0^2 + \left(\frac{\dot{x}_0}{\omega} \right)^2 \right)^{1/2}$

$$\omega = \sqrt{\frac{k}{m}} = 31.42 \text{ rad/sec}$$

$$0.06 \text{ m} = \left(0 + \left(\frac{\dot{x}_0}{31.42} \right)^2 \right)^{1/2}$$

$$\frac{\dot{x}_0^2}{(31.42)^2} = 0.0036$$

$$\dot{x}_0 = 1.89 \text{ m/sec}$$

3.3

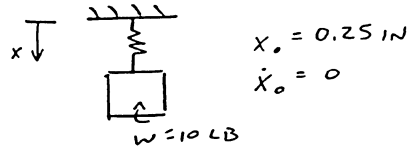

SOLUTION

$$\ddot{x} + \frac{k}{m} x = 0$$

$$k = \frac{W}{x} = \frac{10 \text{ LB}}{0.25 \text{ in}} = 40 \text{ LB/in}$$

$$\omega = \sqrt{\frac{k}{m}}$$

$$\omega = \sqrt{\frac{(40 \text{ LB/in})}{10 \text{ LB} / 32.2 \text{ Ft/s}^2 (12 \text{ in/ft})}}$$

$$\omega = 39.31 \text{ RAD/SEC}$$

3.4

$$\ddot{x}_{\text{max}} = 50 \text{ m/sec}^2$$

$$f = 100 \text{ Hz or } 100 \text{ cps}$$

$$\omega = 2\pi f = 628.32 \text{ rad/sec}$$

3.4 Cont.

a) determine the amplitude of vibration

$$x(t) = X \sin(\omega t + \phi)$$

$$\dot{x}(t) = X \omega \cos(\omega t + \phi)$$

$$\ddot{x}(t) = -X \omega^2 \sin(\omega t + \phi)$$

$$\ddot{x}(t)_{\max} \text{ when } \sin(\omega t + \phi) = 1$$

$$\ddot{x}(t)_{\max} = -X \omega^2$$

$$50 \text{ in/sec}^2 = -X \omega^2$$

$$|X| = \frac{50 \text{ in/sec}^2}{(628.32 \text{ rad/sec})^2} = 1.2666 \times 10^{-4} \text{ in}$$

b) determine max velocity of the mass

$$\dot{x}(t) = X \omega \cos(\omega t + \phi)$$

$$\dot{x}(t)_{\max} \text{ when } \cos(\omega t + \phi) = 1$$

$$\dot{x}(t)_{\max} = X \omega = (1.2666 \times 10^{-4} \text{ in})(628.32 \text{ rad/sec}) = 0.0796 \text{ in/sec}$$

3.5

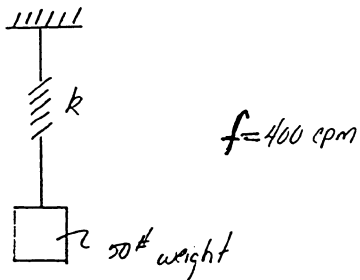

3.5 Cont.

Solution:

$$\omega = 2\pi f = 2513.27 \text{ rad/min or } 41.888 \text{ rad/sec}$$

$$\omega = \sqrt{\frac{k}{m}} \quad m = 50 \# / 32.2 \#/\text{sec}^2 = 1.5528 \# \text{sec}^2/\text{ft}$$

$$41.88 \text{ rad/sec} = \left(\frac{k}{0.1294 \# \text{sec}^2/\text{in}} \right)^{1/2}$$

$k = 227.04 \#/\text{in}$

3.6

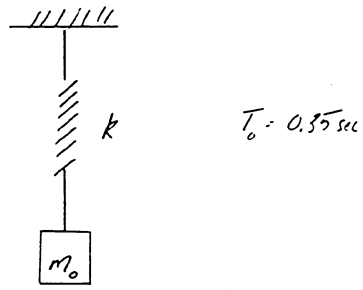

when a 21b mass is added to the system the period increases by 10 percent.

Solution: 21b \rightarrow mass: $\frac{21\text{b}}{32.2 \#/\text{sec}^2} = 6.2112 \times 10^{-2} \text{ lb sec}^2/\text{ft}$
or
 $m = 5.17598 \times 10^{-5} \text{ lb sec}^2/\text{in}$
 $m_f = m_0 + m$
 $T_f = 0.35(1 + 0.1) = 0.385$

eq ① $\omega_0 = \frac{2\pi}{T_0} = \left(\frac{k}{m_0} \right)^{1/2}$

eq ② $\omega_f = \frac{2\pi}{T_f} = \left(\frac{k}{m_f} \right)^{1/2}$

eq ③ $k = \left(\frac{2\pi}{T_0} (m_0)^{1/2} \right)^2$

eq ④ $k = \left(\frac{2\pi}{T_f} (m_f)^{1/2} \right)^2$

3.6 Cont.

equating eq 0 to eq C

$$\frac{2\pi}{T_0} (m_0)^{1/2} = \frac{2\pi}{T_f} (m_f)^{1/2}$$

$$\frac{2\pi}{0.35} (m_0)^{1/2} = \frac{2\pi}{0.385} (m_0 + 5.17598 \times 10^{-3})^{1/2}$$

$$(m_0)^{1/2} = \frac{0.35}{0.385} (m_0 + 5.17598 \times 10^{-3})^{1/2}$$

$$m_0 = \left(\frac{0.35}{0.385}\right)^2 (m_0 + 5.17598 \times 10^{-3})$$

$$0.1736 m_0 = 4.27767 \times 10^{-3}$$

$m_0 = 2.464 \times 10^{-2} \text{ lb sec}^2/\text{in}$ $k = 7.94 \text{ #/in}$

3.7

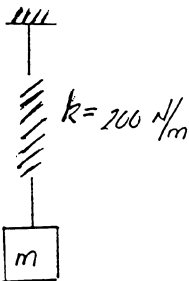

$$f = 50 \text{ Hz}$$

$$f = \frac{\omega}{2\pi} \Rightarrow \omega = 50 \text{ Hz} (2\pi) = 314.16 \text{ rad/sec}$$

$$\omega = \sqrt{\frac{k}{m}}$$

$m = \frac{k}{\omega^2} = \frac{200 \text{ kg m/sec}^2}{(314.16 \text{ rad/sec})^2} = 2.026 \times 10^{-3} \text{ kg}$ <p style="text-align: right;">or 2.026 g</p>

3.8

$$\dot{x}(t)_{\max} = 10 \text{ in/sec}$$

$$T = 1.5 \text{ sec}$$

$$x_0 = 3.0 \text{ in}$$

a) determine the amplitude of free vibration

$$\dot{x}(t) = X\omega \cos(\omega t + \phi)$$

$$\dot{x}(t)_{\max} \text{ when } \cos(\omega t + \phi) = 1$$

$$\dot{x}(t)_{\max} = X\omega \text{ where } \omega = \frac{2\pi}{T} = 4.1888 \text{ rad/sec}$$

$$10 \text{ in/sec} = X(4.1888 \text{ rad/sec})$$

$$X = 2.387 \text{ in}$$

b) determine the maximum acceleration of the mass

$$\ddot{x}(t) = -X\omega^2 \sin(\omega t + \phi)$$

$$\ddot{x}(t)_{\max} \text{ when } \sin(\omega t + \phi) = 1$$

$$\ddot{x}(t)_{\max} = -X\omega^2 = -41.888 \text{ in/sec}^2 \text{ or } [41.888 \text{ in/sec}^2] \text{ magnitude}$$

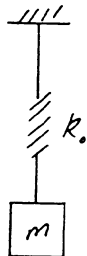
3.9

$$f_0 = 10 \text{ Hz}$$

$$k_f = k_0 + 5 \text{ lb/in}$$

$$f_f = 10(1 + .25) = 12.5 \text{ Hz}$$

3.9 Cont.

a) determine the spring constant for the original system (k_0)

$$f_0 = \frac{\omega_0}{2\pi} \Rightarrow \omega_0 = f_0 2\pi = 10(2\pi) = 20\pi = \sqrt{\frac{k_0}{m}}$$

$$m = \frac{k_0}{(20\pi)^2} \quad \text{eq ①}$$

$$f_f = \frac{\omega_f}{2\pi} \Rightarrow \omega_f = 12.5(2\pi) = 25\pi = \sqrt{\frac{k_f}{m}}$$

$$m = \frac{k_f}{(25\pi)^2} = \frac{k_0 + 5 \text{ lb/in}}{(25\pi)^2} \quad \text{eq ②}$$

equating eq ① to eq ②

$$\frac{k_0}{(20\pi)^2} = \frac{k_0 + 5}{(25\pi)^2} \Rightarrow 0.5625 k_0 = 5$$

$$\boxed{k_0 = 8.89 \text{ lb/in}}$$

b) determine the mass of the original system

$$m = \frac{k_0}{(20\pi)^2} = \frac{8.89 \text{ lb/in}}{(20\pi \text{ rad/sec})^2} = 2.25186 \times 10^{-3} \text{ lb sec}^2/\text{in}$$

or

$$\boxed{m = 2.7021 \times 10^{-2} \text{ lb sec}^2/\text{ft}}$$

3.10

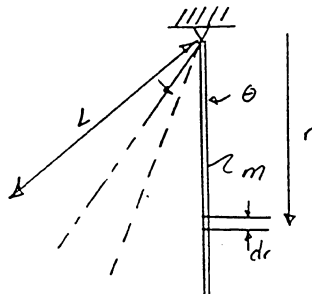

$$T = 0.75 \text{ sec}$$

$$\omega = \frac{2\pi}{T} = \frac{2\pi}{3/4} = \frac{8\pi}{3}$$

3.10 cont.

$$T = \frac{2\pi}{\omega} = 2\pi \left(\frac{2L}{3g} \right)^{1/2}$$

$$\frac{T^2}{4\pi^2} = \frac{2L}{3g} \Rightarrow L = \frac{3g T^2}{8\pi^2} = \frac{3g (3/4)^2}{8\pi^2}$$

$$L = \frac{27g}{128\pi^2} = 8.5 \text{ in}$$

3.11

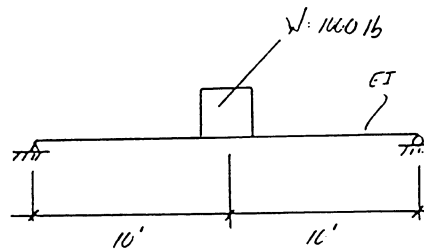

$$E = 29,000 \text{ ksi}$$

$$I = 1830 \text{ in}^4$$

$$E = 29 \times 10^6 \text{ psi}$$

$$x_0 = 1.5 \text{ in}$$

$$v_0 = \dot{x}_0 = 4.5 \text{ in/sec}$$

a) determine the natural period of vibration

$$k = \frac{48EI}{L^3}$$

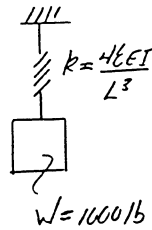

$$m = \frac{1000 \text{ lb}}{32.2 \text{ ft/sec}^2} = 31.056 \text{ lb sec}^2/\text{ft}$$

$$= 2.588 \text{ lb sec}^2/\text{in}$$

$$\omega = \left(\frac{k}{m} \right)^{1/2} = \left(\frac{48EI}{mL^3} \right)^{1/2}$$

$$= \left(\frac{48 (29 \times 10^6 \text{ psi/in}^2) (1830 \text{ in}^4)}{(2.588 \text{ lb sec}^2/\text{in}) (24 \text{ in})^3} \right)^{1/2} = 266.84 \text{ rad/sec}$$

$$T = \frac{2\pi}{\omega} = 0.02355 \text{ sec}$$

3.11 Cont.

Energy Method

(kinetic energy) "T"

$$T = \frac{1}{2} m \dot{v}^2 = \frac{1}{2} \int_0^L \frac{m}{L} (r(\sin\theta))^2 dr$$

$$= \frac{1}{2} \left[\frac{mr^3}{3L} \sin^2\theta \right]_0^L = \frac{1}{2} \frac{mL^2}{3} (\sin\theta)^2$$

$$\sin\theta = \dot{\theta}$$

$$= \frac{mL^2}{6} \dot{\theta}^2$$

(potential energy) "V"

$$V = \int_0^L \frac{m}{L} g r (1 - \cos\theta) dr = \left[\frac{mg r^2}{2L} (1 - \cos\theta) \right]_0^L$$

$$= \frac{mgL}{2} (1 - \cos\theta)$$

$$\frac{d(T+V)}{d\theta} = 0 = \frac{mL^2}{3} \dot{\theta} \ddot{\theta} + \frac{mgL}{2} \sin\theta \dot{\theta}$$

$\sin\theta = \theta$ small disp

$$\frac{mL^2}{3} \ddot{\theta} + \frac{mgL}{2} \theta = 0$$

$$\ddot{\theta} + \left(\frac{3mgL}{2mL^2} \right) \theta = 0$$

$$\ddot{\theta} + \left(\frac{3g}{2L} \right) \theta = 0$$

(equation of motion)

$$\omega = \sqrt{\frac{3g}{2L}}$$

3.11 cont.

b) determine max displacement

$$x(t) = X \sin(\omega t + \phi)$$

$$x(t)_{\max} = X = \left((x_0)^2 + \left(\frac{\dot{x}_0}{\omega} \right)^2 \right)^{1/2}$$

$$x(t)_{\max} = X = \left((1.5)^2 + \left(\frac{4.5}{266.84} \right)^2 \right)^{1/2} = 1.5 \text{ in}$$

c) determine max velocity

$$\dot{x}(t) = X \omega \cos(\omega t + \phi)$$

$$\dot{x}(t)_{\max} = X \omega = (1.5)(266.84) = 400.26 \text{ in/sec}$$

d) determine the max. acceleration of the mass

$$\ddot{x}(t) = -X \omega^2 \sin(\omega t + \phi)$$

$$\ddot{x}(t)_{\max} = -X \omega^2 = -(1.5)(266.84)^2 = -106805.38 \text{ in/sec}^2$$

or

$$106805.38 \text{ in/sec}^2 \text{ magnitude}$$

e) determine phase angle

$$\phi = \tan^{-1} \left(\frac{x_0 \omega}{\dot{x}_0} \right) = 89.36^\circ$$

3.12

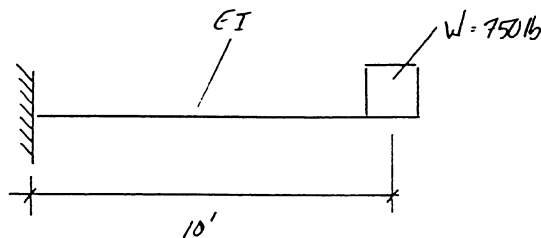

$$E = 30,000 \text{ ksi} \\ = 30 \times 10^6 \text{ psi} \\ I = 2500 \text{ in}^4$$

$$x_0 = 20 \text{ in}$$

$$v_0 = \dot{x}_0 = 3.0 \text{ in/sec}$$

3.12 Cont.

a) determine the natural frequency of free vibration

$$k = \frac{3EI}{L^3}$$

$$m = \frac{750 \text{ lb}}{32.2 \text{ ft/sec}^2} = 23.29 \text{ lb sec}^2/\text{ft}$$

$$\omega = \left(\frac{k}{m}\right)^{1/2} = \left(\frac{3(30 \times 10^6)(2500)}{(1.941)(120)^3}\right)^{1/2} = 259 \text{ rad/sec} = 1.941 \text{ lb sec}^2/\text{in}$$

$$f = \frac{\omega}{2\pi} = 41.22 \text{ Hz}$$

b) determine the max displacement, velocity, & acceleration of the mas.

$$\begin{aligned} x(t)_{\max} &= x = \left(x_0^2 + \left(\frac{x_0}{\omega}\right)^2\right)^{1/2} = 2 \text{ in} \\ \dot{x}(t)_{\max} &= x\omega = 518 \text{ in/sec} \\ \ddot{x}(t)_{\max} &= x\omega^2 = 134162 \text{ in/sec}^2 \end{aligned}$$

c) determine phase angle

$$\psi = \tan^{-1}\left(\frac{x_0\omega}{x_0}\right) = 89.67^\circ$$

DISPLACEMENT VS. TIME

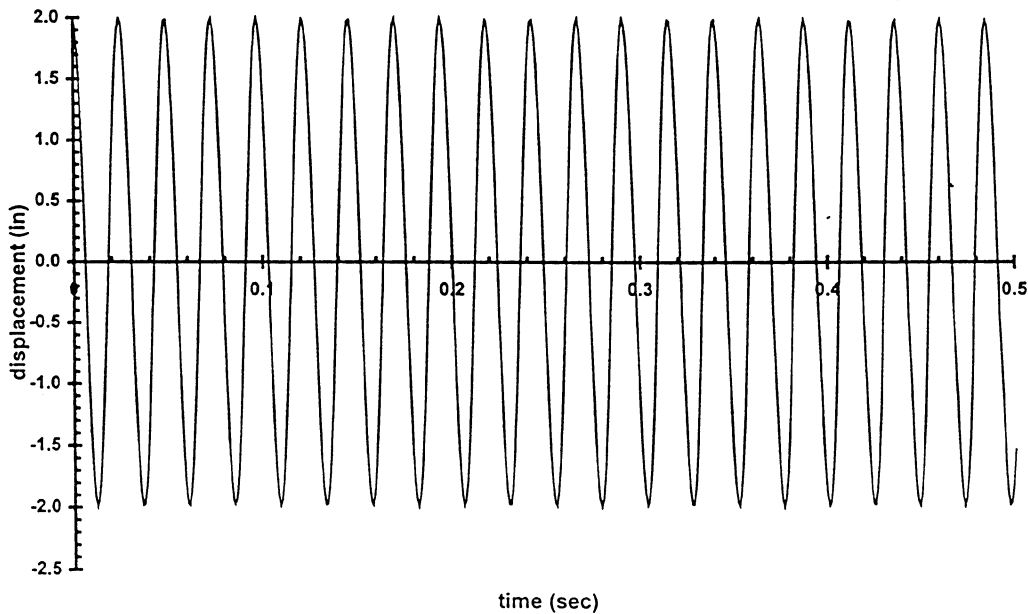

3.12 Cont.

VELOCITY VS. TIME

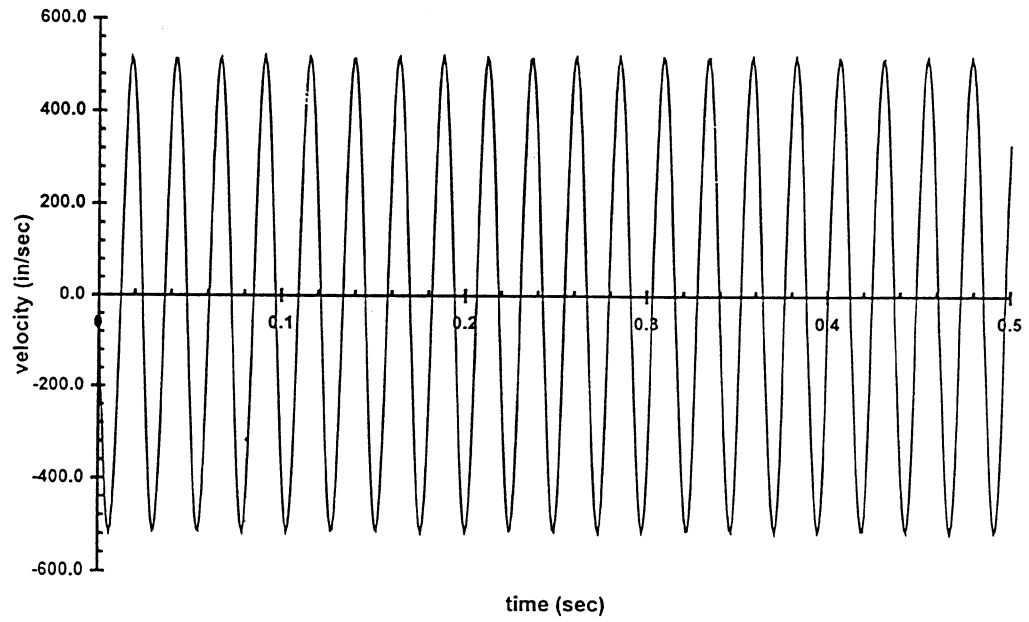

ACCELERATION VS. TIME

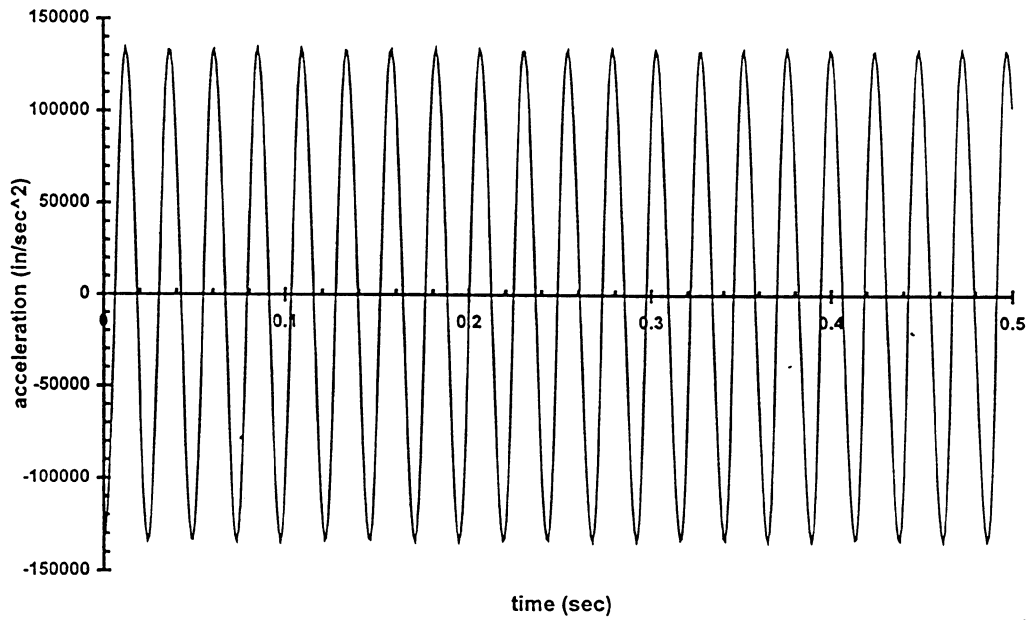

3.13

$$M = \frac{100}{386.4} = 0.258 \quad \frac{\text{lb} \cdot \text{s}^2}{\text{in}}$$

$$y_0 = 0$$

$$T = 0.15 = \frac{2\pi}{\omega}$$

$$\therefore \omega = \frac{2\pi}{0.15} = 41.88 \text{ rad/sec}$$

$$41.88 = \sqrt{\frac{k}{m}} = \sqrt{\frac{k}{0.258}}$$

$$k = 452.7 \text{ lb/in} \quad (a)$$

$$X = \sqrt{y_0^2 + \left(\frac{V}{\omega}\right)^2}$$

$$1.5^2 = \frac{V^2}{(41.88)^2}$$

$$V_0 = 62.82 \text{ in/sec} \quad (b)$$

$$\phi = \tan^{-1} \frac{y_0}{V_0/\omega} = 0$$

$$\therefore x = 1.5 \sin 41.88t$$

$$\dot{x} = 1.5 (41.88) \cos 41.88t$$

$$\ddot{x} = -1.5 (41.88)^2 \sin 41.88t$$

$$\text{at } t = 0.41 \text{ sec} \quad (c)$$

$$x = -1.49 \text{ in} \quad \dot{x} = -677 \text{ in/sec} \quad \ddot{x} = 2615.6 \text{ in/sec}^2$$

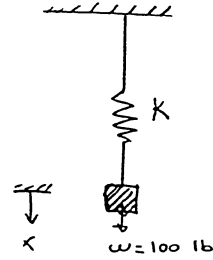

3.14

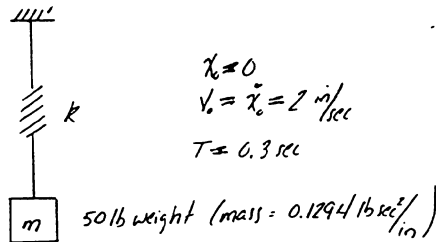

3.14 Cont.

a) determine the spring constant (k)

$$\omega = \left(\frac{k}{m}\right)^{1/2}; \quad T = \frac{2\pi}{\omega} = 0.3 \text{ sec} \Rightarrow \omega = \frac{20\pi}{3}$$

$$k = \omega^2 m = \left(\frac{20\pi}{3}\right)^2 (0.1294) = 56.76 \text{ lb/in}$$

b) determine the amplitude of vibration

$$X = \left(\left(\frac{x_0}{\omega}\right)^2 + \left(\frac{\dot{x}_0}{\omega}\right)^2 \right)^{1/2} = \left(\left(\frac{6}{20\pi}\right)^2 \right)^{1/2} = \frac{6}{20\pi} = 9.549 \times 10^{-2} \text{ in}$$

c) determine the velocity & acceleration of the mass @ $t = 0.5 \text{ sec}$

$$\phi = 0$$

$$\dot{x}(t) = X\omega \cos \omega t$$

$$\dot{x}(0.5 \text{ sec}) = \frac{6}{20\pi} \left(\frac{20\pi}{3}\right) \cos\left(\frac{20\pi}{3}\right)(0.5) = -1.0 \text{ m/sec}$$

$$\ddot{x}(t) = -X\omega^2 \sin \omega t$$

$$\ddot{x}(0.5 \text{ sec}) = -\left(\frac{6}{20\pi}\right) \left(\frac{20\pi}{3}\right)^2 \sin\left(\frac{20\pi}{3}\right)(0.5) = 36.28 \text{ in/sec}^2$$

3.15

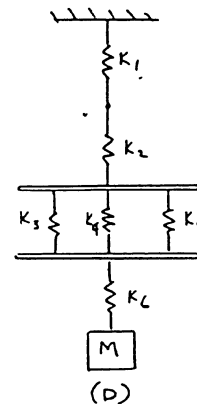
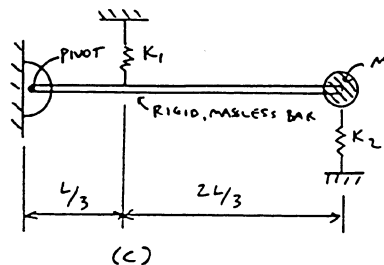
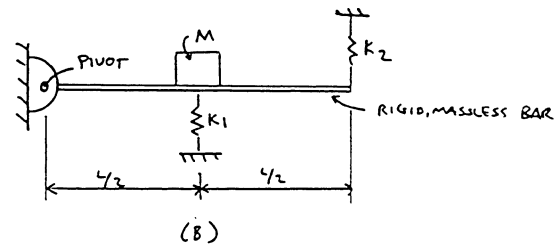
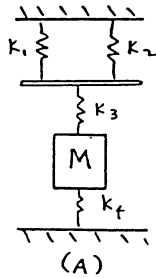

3.15 Cont.

SYSTEM (B)

(A) EQUIVALENT STIFFNESS, k_e

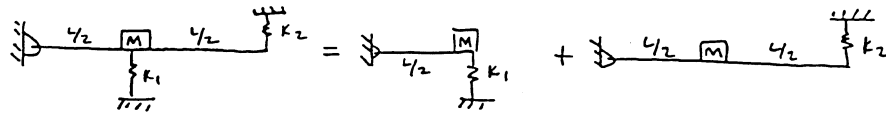

$$k_e = k_1 \left(\frac{L/2}{L/2} \right)^2 + k_2 \left(\frac{L}{L/2} \right)^2$$

$$k_e = k_1 + 4k_2$$

(B) EQUATION OF MOTION

$$\ddot{x} + \frac{k_1 + 4k_2}{M} x = 0$$

(C) NATURAL FREQUENCY

$$\omega = \sqrt{\frac{k_1 + 4k_2}{M}}$$

SYSTEM (C)

(A) EQUIVALENT STIFFNESS, k_e

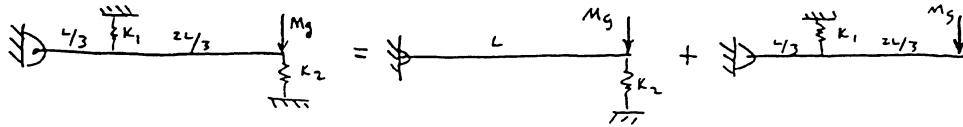

$$k_e = k_2 \left(\frac{L}{L} \right)^2 + k_1 \left(\frac{L/3}{L} \right)^2$$

$$k_e = k_2 + \frac{k_1}{9}$$

(B) EQUATION OF MOTION

$$\ddot{x} + \frac{k_1/9 + k_2}{M} x = 0$$

(C) NATURAL FREQUENCY

$$\omega = \sqrt{\frac{k_1/9 + k_2}{M}}$$

SYSTEM (D)

$$\frac{1}{k_{e1}} = \frac{1}{k_1} + \frac{1}{k_2}$$

$$\frac{1}{k_{e1}} = \frac{k_1 + k_2}{k_1 k_2}$$

$$k_{e1} = \frac{k_1 k_2}{k_1 + k_2}$$

$$k_{e2} = k_3 + k_4 + k_5$$

